

**TALL ABŪ AL-KHARAZ**  
**THE SWEDISH JORDAN EXPEDITION 1995-1996**  
**SIXTH AND SEVENTH SEASON PRELIMINARY EXCAVATION REPORT**

by

Peter M. Fischer

with a contribution by Helena Ingemarsdotter

### **Introduction**

Excavations, directed by the author, were carried out at Tall Abū al-Kharaz, north of Wādī al-Yābis and about 4 km east of the River Jordan, from 24 September - 26 October 1995, and from 15 March - 21 April 1996. The members of the 1995 team were Hikmat Ta'ani, the representative of the Department of Antiquities of Jordan from Irbid, who also acted as trench master of Trenches XXVIIA, XXVIID and XXVIIE and foreman in the field. Other trench masters were Dieter Vieweger, Kirchliche Hochschule, Wuppertal (Trenches XXVIB, XXVIIC and XXVIII A), Susan Gomzi (Trench XXVIIB) and Sara Viklund (Trenches XXVIB and IX) both from Göteborg University, and Christopher König, University of Bonn, together with Abdulah Ahmed Khrasat from the Jordan University in Amman (Trenches XXVIA and XXIV). The members of the 1996 team were Hikmat Ta'ani (Trenches XXXI-III), Kristian Göransson (Trench XXIXA), Jennifer Randolph (Trench XXIXB), Susan Gomzi (Trench XXXA) and Helena Ingemarsdotter (Trench XXXB). The expedition's architect was Muwafaq Al-Bataineh, the draughtsperson Lamia Khoury and the photographer Hussein Debajeh, all from Yarmouk University. The team was further supported by 25 skilled workers from Pella and al-Mashari'.

The objectives of the two seasons were (for the location of areas and trenches see Fig. 1):

1. The further excavation of Area 1 north and west of the trenches which were

partly excavated in 1989 (Fischer 1991: 67-104), in order to investigate the area inside the defence systems, which date mainly from the Early and Late Bronze Age periods.

2. Complementary excavations in Area 2, Trench IX, and Area 9, Trench XXIV.
3. The investigation of the uppermost plateau of the tall (Area 10).

Information concerning excavation and sampling techniques, and electronic support, may be found in the preliminary reports previously published in *ADAJ* (Fischer 1991, 1993-96). In the description below the results are presented area by area, and period by period, from colluvial soil.

### **RESULTS OF THE 1995-96 SEASONS**

#### **Area 1: Trenches XXVIA-B, XXVIIA-E and XXVIII A, XXIXA-B and XXXA-B**

The trenches lie within the Grids NN/PP 29/30 (see Fischer 1991). The co-ordinates of the north-east corner of Trench XXVIA correspond to E 206.130 and N 200.636± m according to the Palestine Grid Co-ordinate system. This part of the tall slopes from east to west approximately 1.5 m in 10 m, while from north to south it is almost flat.

#### **Colluvial soil**

The colluvial soil is 20-30 cm deep. Parts of stone walls which originate from the Iron Age and post-Iron Age periods are visible on the surface. The pottery is a mixture of all the periods found at Tall Abū al-Kharaz: the post-Iron Age, the late Iron Age, the Late Bronze Age and the Early Bronze Age periods are best represented.

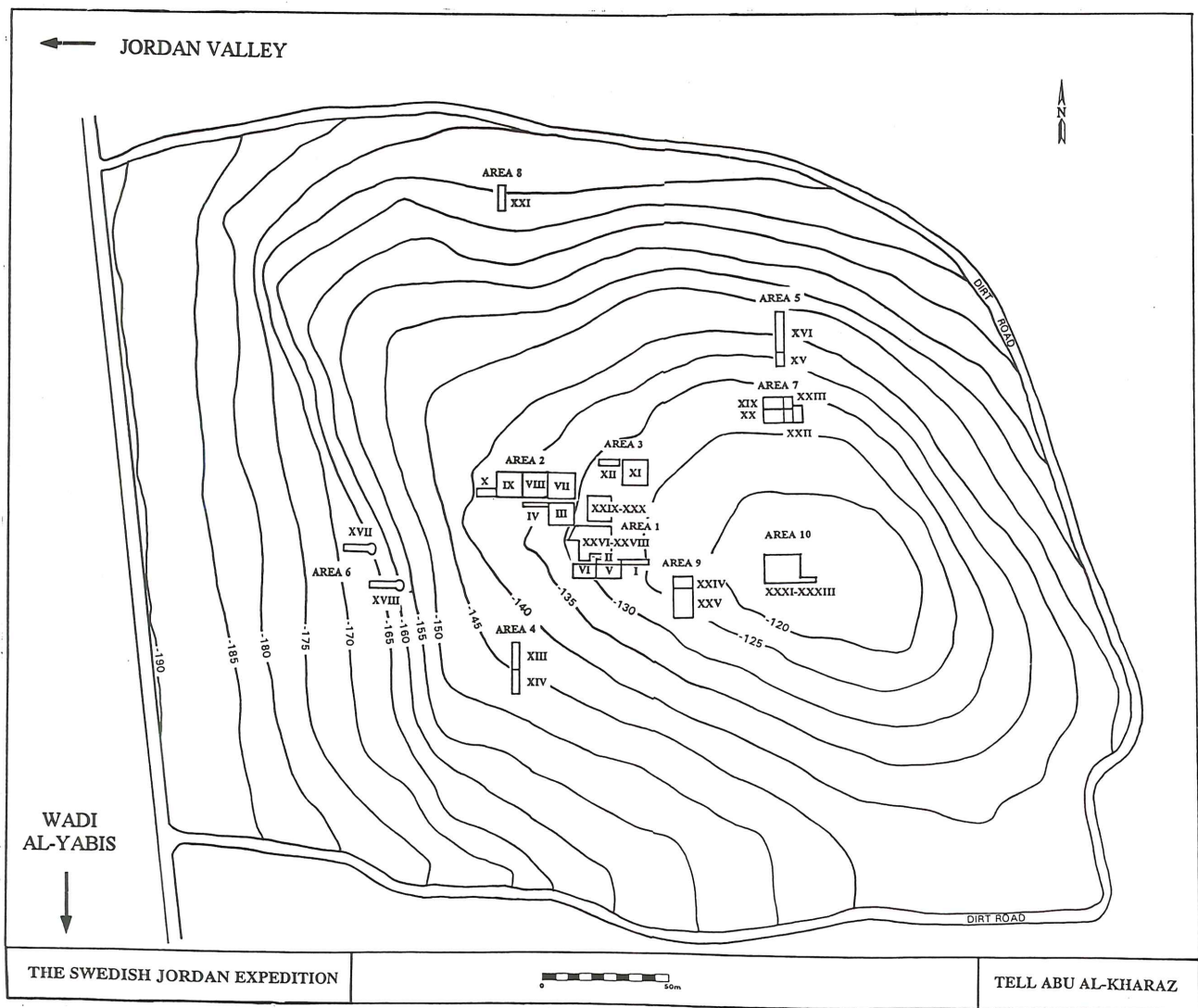

1. Tall Abū al-Kharaz 1989-96. Sketch of areas and trenches.

## Iron Age

### *Stratum 1A*

The most recent architectural phase is represented by two walls approximately 0.8 m wide: Wall (W) 357 runs north-north-east to south-south-west and W 325 at a right angle to the east-south-east, thereby forming a corner in the south-west. The somewhat smaller inner wall W 324 runs parallel to W 357, 2.5 m from it. W 325 is the same "city" wall as was found in 1989 in the west of Area 1 and numbered Wall 4 (Fischer 1991: 73) and in Area 9, where it is numbered W 221. Its total length is ca 350 m and it encircles the upper part of the tall. The orientation of the walls is different from that

in the earlier Iron Age phases, that is nearer to north-south. Assuming a superstructure of mudbrick the outer walls may have served as a "city" wall, maybe as an additional line of defence.

Most of the pottery from this stratum consists of Late Iron Age forms but there are also some intrusive sherds, mainly of Abbasid origin. No other important finds were made. The preliminary date of this phase points to the late part of the Iron Age, but it is likely that the foundation walls were also used during post-Iron Age periods.

### *Stratum 1B*

The dominating architecture of this

phase resembles similar structures from Area 7, Strata 3 and 4, which were excavated in 1993 (Fischer 1995). Those structures were interpreted as towers from two successive periods but erected within a relatively short time. The partially excavated building with a central courtyard seems to be square, with the south-east side ca 10 m long. It is built against the city wall from the Late Bronze Age period. A gate in the south-west part of the city wall leads into the courtyard. The 1.2 m wide gate appears to be an opening in the city wall, but it is in fact built on top of the older city wall. The older wall was used to approach the gate. The distance between the outer wall, (0.6 m wide) and the inner wall (0.5 m wide), which encloses the courtyard, is 1.6 m. There is an entrance from the south-east to the space between the two walls, which is stone-paved and has a bench against the outer wall, but with a 0.3 m wide sewer left for drainage. Another entrance of the courtyard, is from the north-west. The central courtyard seems to be square. What was certainly a loom standing in the north-eastern corner of the courtyard close to the entrance to the stone-paved room: spindle whorls, cooking pots and other vessels, for example a black juglet, mortars and pestles, knives and arrow heads, suggest that the courtyard was used for various purposes, food preparation and weaving clearly being amongst them. A crater standing on three loop-handles belongs to this phase (see below, Fig. 3: 1).

An interesting find from the courtyard of the building is a nicely finished and once burnished limestone object usually called a cosmetic palette (Fig. 2), a not uncommon find in Iron Age II Palestinian contexts (among others Ṭawilān, Tall as-Sa'idiyya, Hazor, Kinneret, Megiddo, Samaria, Shechem, Tall Beit Mersim, Tall en-Nasbeh, Gezer, Ramat Rahel, Gerar and Beer-Sheba; see references in Thompson 1971: 61-70). It was found well-preserved and only slightly damaged, although it has been exposed to

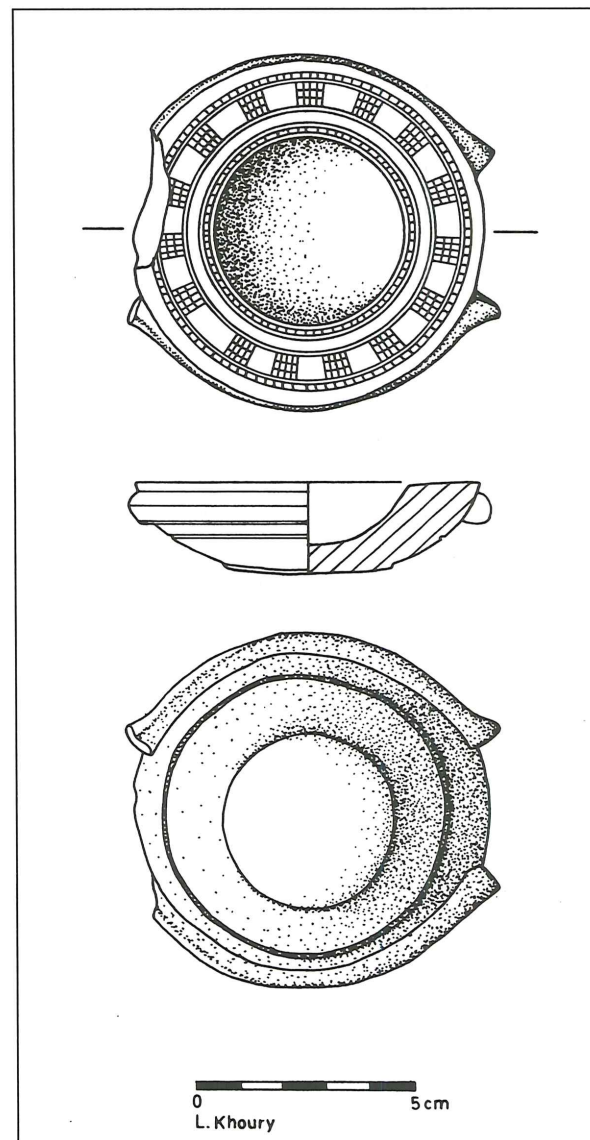

2. Cosmetic palette, burnished and incised limestone; Stratum 1B, later part of Iron Age.

fire. The convex side is divided into three zones. There are two double, trumpet-like, ledge handles which are usually found as a plastic decoration on ceramic vessels from the later part of the Iron Age. The other side is flat, with a deep depression in the centre of half the diameter of the object. The flat side is decorated with a geometrical pattern. The object may very well have been used for grinding and mixing cosmetics or medicines, which would have been placed in the central depression. However, there must have been a kind of container for the cosmetics or medicines. It seems likely that the

object was also used as a lid with handles when turned upside down to cover a container of, for example, wood, which has not been preserved. The incised pattern may have had only a decorative function, although other functions such as that of a calendar are a possibility.

It is not unlikely that the building had more than one storey. The function of this building seems to be that of an inhabited tower, maybe for the guards' families. It was destroyed by fire. The corner of another building is to the north-east. There is a cistern-like, 2 m deep stone-walled construction in the south-east.

Another house to the west could be approached from a 2.5 m wide gate, two door sockets of which were still *in situ*.

A tentative date for this phase is the later part of the Iron Age.

### Stratum 1C

The oldest Iron Age phase in this area is represented by a wall at least 15 m long running parallel to the reused Late Bronze Age city wall at a distance of ca. 4 m. Another wall is built at a right angle to the city wall. The area enclosed by these walls is partly stone-paved. It is impossible at the present stage of excavation to say anything about the possible function of this construction. The pottery suggests a date within the earlier half of the Iron Age. The rim and handles of a vessel (incense burner?) with a plastic, double-snake decoration belong to this phase (Fig. 3: 2).

## Late Bronze Age

### Stratum 2A

The architectural remains from the most recent phase of the Late Bronze Age are scanty because of Iron Age disturbances. They can only be seen in the north-eastern corner of the area in the form of a room and a courtyard with an oven and a hearth(?). The pottery points to a date within the second half of the Late Bronze Age.

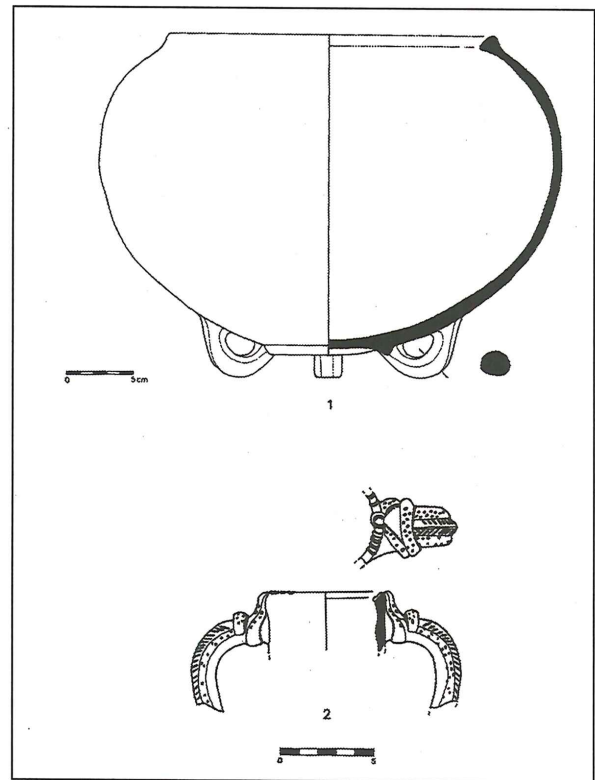

### 3. Iron Age.

1. XXVIIA1L106, crater standing on three loop handles, wheel-made, hard-fired, grey clay, coarse mainly white inclusions (the sizes of the inclusions refer to the Wentworth scale, Wentworth 1922, 1933), self slip; Stratum 1B, later part of Iron Age.
2. XXXB1CL303N1017, rim and handles of vessel with plastic double-snake decoration (incense burner?), wheel-made/hand-made, hard-fired, light brown clay, medium-coarse mainly black inclusions, self slip, traces of red paint; Stratum 1C, first half of Iron Age.

### Stratum 2B

Substantial architecture, both new and reused, was found within this phase. The city wall complex on the south and west sides is of the casemate type with outward-projecting corners: one to the west and the other to the south-west. The city wall on the south side, partly excavated in 1989 (Wall 9), was further exposed (Walls 333 and 334; partly shown in Fig. 4). The excavations reached the city wall also in the west part of the area (Wall 358) at the end of the season. The distance between the inner and outer walls is ca. 2 m on the south side and ca. 1 m on the west. The space between the inner



and outer walls on the south side contained only filling material, whereas the second floor level of the casemate room on the west contained everyday artefacts, for example pottery, a toggle pin and quite a large complete dagger. The latter is a long narrow room which could be approached from the north-east through an entrance 0.7 m wide. Another partly preserved room was found to the south-east of the western casemate room.

A commercial complex, very likely a bakery, was exposed in the centre of the area inside the city wall (Fig. 4, northern part). A number of rooms were found north-east of the city wall. There is a stone-paved room, ca. 3 x 5 m large with a stone-built grain silo, circular in shape and 1.4 m in inner diameter. It belongs certainly to the bakery. To the north-east of the silo-room there is a partly plastered room, 1.6 x 2 m wide, with an 0.6 m wide entrance from the south-east. The plastered floor was probably used to prepare the dough. There is another room, or possible a roofed courtyard to the north-east. It contains an oven and grinding objects. From it there is an entrance with a door socket to the north-west (this part is not yet excavated). Three well-constructed ovens were found in a row in the northern part of the area: two inside another room (1.8 x 2.4 m) with a clay bench opposite, and one in a niche just outside the 0.8 m wide entrance to this room. The ovens were reinforced with broken pottery. An open area west of the oven-room is enclosed by a long wall with an attached stone bench in the north-west and the western casemate room. The lower part of the cistern described above may have been constructed in the Late Bronze Age. The function of this area is apparently commercial. It may be the city's central bakery. It seems unlikely that the large silo-room and the four ovens were used by a single household. The pottery points to a date within the first half of the Late Bronze Age (Fig. 5).

### Stratum 2C

Most of the architecture described above was constructed in this, the earliest, Late Bronze Age phase: for example the city

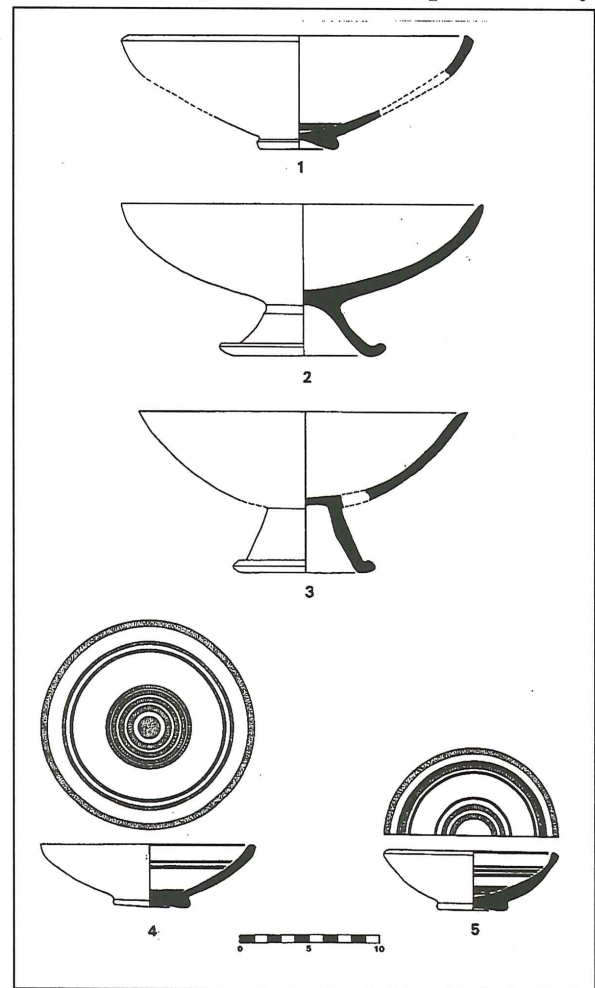

5. Late Bronze Age. Stratum 2B, first half Late Bronze Age.

1. XXVIIA2L146-3, bowl, wheel-made, hard-fired, reddish-brown clay, thick dark grey core, coarse mainly black inclusions, reddish-brown slip, dark reddish-brown decoration.
2. XXVIIA2L154-1, chalice, wheel-made, hard-fired, light brown clay, pinkish-yellow slip, horizontally burnished.
3. XXVIIA2L146-4, chalice, wheel-made, medium-hard-fired, yellowish-brown clay, thick grey core, coarse mainly black inclusions, thick red slip, burnished.
4. XXVIB2L133-1, bowl, wheel-made, medium-hard-fired, light brown clay, a few coarse grey inclusions, yellowish-brown slip, chocolate brown decoration.
5. XXVIIA2L146-5, bowl, wheel-made, medium-hard-fired, brown clay, greyish-brown core, coarse mainly black and white inclusions, pinkish-white slip, chocolate brown decoration.

walls, the casemate rooms and the room with the ovens. An oven north-west of the "silo-room" (a silo was not found in this phase) should be mentioned. It is about 0.9 m in diameter and reinforced with high-quality Chocolate-on-White Ware (also bichrome). The western casemate room also contains bichrome Chocolate-on-White Ware. This phase dates from the very beginning of the Late Bronze Age according to the pottery (Figs. 6 and 7).

*Stratum 2D*

This stratum contains no architecture but has four pits, containing among other finds very early Late Bronze Age pottery. One hypothesis is that the settlers occupying the site for the first time in ca. 1300 years (the last previous occupational phase is from the Early Bronze Age II) built their houses higher up the tall and used the area for dumping rubbish.

**Early Bronze Age**

The Early Bronze Age strata were only exposed in those trenches where no substantial Late Bronze Age architecture was discovered (the LB remains were left for future consolidation). The phases follow the well-known occupational pattern during the Early Bronze Age at Tall Abū al-Kharaz: the earliest phase (Phase I with subphases) belongs to the later part of the Early Bronze Age I and is followed by periods of extensive occupation during the Early Bronze Age II (Phase II with subphases; also called "Main Phases" in the earlier reports). Phase III was a period of squatter occupation after the big catastrophe, which is very likely to have been caused by an earthquake or a series of earthquakes. In general the walls are orientated north-south and east-west (cf. the differently oriented architecture of the later periods).

*Strata 3 A-B (Phases III-II)*

Parts of a curvilinear building were exposed. A stone-built hearth was found in the

"apses". A grain silo, ca. 1 m in diameter, adjoins the building to the west. It seems that this building was used in more than one

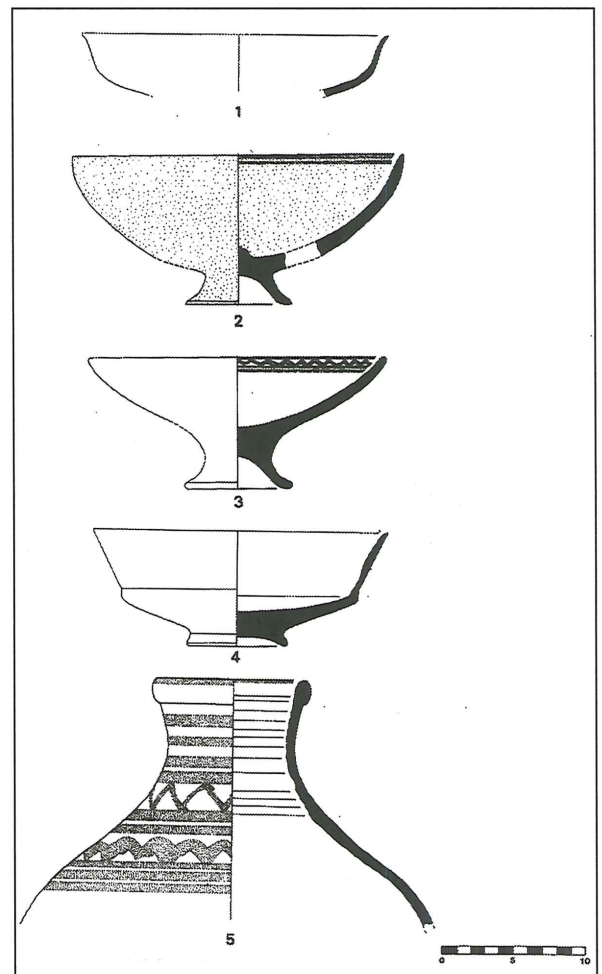

6. Late Bronze Age. Stratum 2C, beginning Late Bronze Age.

1. XXVIID2L232-1, Chocolate-on-White (Egg-shell Ware) bowl, wheel-made, very hard-fired, light red clay, a few medium-fine white inclusions, thick white slip int. and ext., wheel-burnished.
2. XXVIIIE2-3, bowl, wheel-made, hard-fired, light brown clay, medium coarse multicoloured inclusions, thick orangish-brown slip, dark red decoration.
3. XXVIIIE2-2, Chocolate-on-White chalice, wheel-made, hard-fired, greyish-brown clay, medium-coarse white inclusions, thick yellowish-white slip, brown decoration.
4. XXVIID2L231-1, carinate bowl, wheel-made, hard-fired, brown clay, light grey core, only a few coarse inclusions, yellowish-brown slip.
5. XXVIIIB2L173-1, jug, wheel-made, hard-fired, pinkish-brown clay, light brown core, coarse mainly grey inclusions, yellowish-brown slip, brownish-red decoration.

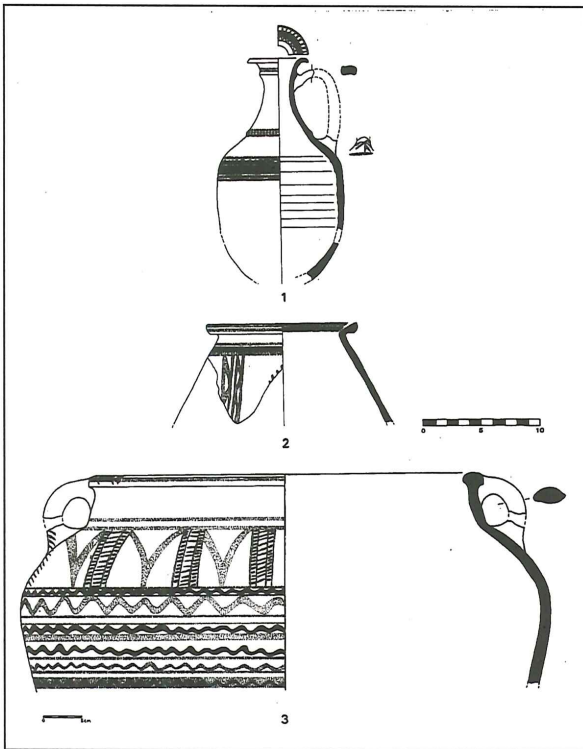

7. Late Bronze Age. Stratum 2C, beginning Late Bronze Age.

1. XXVIIC2L221-4, Chocolate-on-White Bichrome jug, wheel-made, very hard-fired, pink clay, grey core, fine, thick white-pink-grey-yellow slip, chocolate brown and black decoration.
2. XXVIIB2L160-2, Chocolate-on-White Bichrome biconical jug, wheel-made, hard-fired, light yellowish-brown clay, medium coarse mainly grey inclusions, pinkish-yellow slip, chocolate brown and black decoration.
3. XXVIIB2L160-3, Chocolate-on-White Bichrome krater, wheel-made, hard-fired, light brown clay, medium coarse mainly grey inclusions, thick yellowish-white slip, chocolate brown and black decoration.

phase. A room with at least 15 vessels, some of them containing a lot of grain, was excavated in the southern part of the area. It was covered by the fallen roof of straw and wood, and a thick layer of ash. Some of the vessels and parts of the mudbrick walls were vitrified by the heat. There was a hearth in the middle of the room. A mudbrick wall from a destroyed house belonging to the previous phase was re-used as a bench on which small vessels were placed. A copper or bronze chisel lay just below the bench. Another well preserved

room to the north contained pottery and grinding tools of basalt (for some vessels see Fig. 8) together with the remains of a loom: ten loom weights were found in a row. The scanty remains of a wooden construction lay around the loom weights.

*Strata 3C-D (Phase I)*

Well-preserved domestic architecture belongs to this phase. A number of rooms with stone foundations, door sockets and thresholds were found *in situ*. Scanty remains of two curved walls were found which probably belong to apsidal buildings. There is no evidence in this area that the earliest architectural phase at the site came to a violent end. Two objects beside storage jars with grain should be referred to: a complete red pattern-burnished, beautifully finished, almost complete jug, and a copper or bronze axe with rounded upper part (for some vessels, see Fig. 8).

**Area 10: Trenches XXXI-III.**

These three trenches (10 x 7.5 m) lie within an almost flat area and include the summit of Tall Abū al-Kharaz (VV/WW 30/31 within our grid system). The coordinates of the summit correspond to E 206196.54 and N 200623.07 according to the Palestine Grid Co-ordinate system.

Parts of a very well constructed monumental building, "The White Building", which is covered with white plaster on the outside, were exposed (Fig. 9; see also below). The stratigraphy is somewhat puzzling: the two rooms hitherto exposed contained only Iron Age pottery (Fig. 10), but the area within a few decimetres of the outer walls produced only Late Roman pottery (Fig. 11). The north-western room contained an ostrakon, whose inscriptions show parallels with other Transjordanian and Hebrew examples. (Fig. 11: 1; see e.g. some undeciphered from the ninth and eighth century inscriptions at Dayr 'Allā; pers. comm. G. van der Kooij; see also the forthcoming



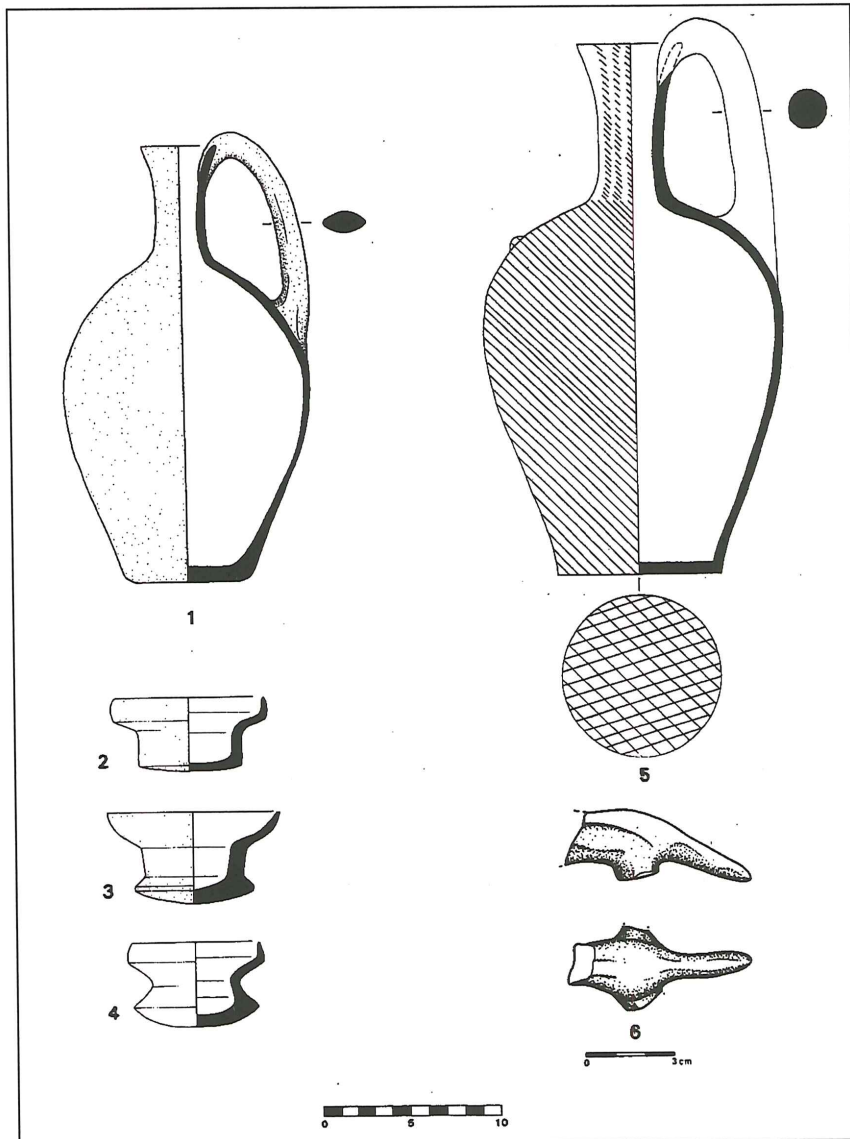

1. XXIXA3AL328N1022, jug (Metallic Burnished Ware), coil-built, wheel-finished, very hard-fired greyish-brown clay, mainly white coarse inclusions, red slip, vertically burnished, well finished.
2. XXXA3CL354N1049, cup/lid, Type 1, wheel-made, hard-fired, light brown clay, fine inclusions, traces of red slip ext.
3. XXXA3CL354N1048, cup/lid, Type 2, wheel-made, soft-fired, light brown clay, grey core, multi-coloured coarse inclusions, traces of reddish-brown slip and burnish ext.
4. K96XXXA3CL315N1021, cup/lid, Type 3, wheel-made, hard fired, yellowish-brown clay, fine inclusions, traces of yellowish-brown wash ext.
5. K95XXVIIIB3L257-2, jug with vertical handle, coil-built, the neck and rim wheel-made, medium-hard fired, light brown clay, mainly white medium coarse inclusions, red slip, burnished: vertically pattern burnished on the neck, the body shows a high lustre (almost glazed), the base is net-pattern burnished, excellently finished.
6. XXXA3BL342N1040, animal figurine, hand-made, very hard-fired, light-brown clay, fine inclusions, traces of dark brown-black wash.

8. Early Bronze Age II and IB: 1, Phase II = Early Bronze Age II; 2-6, Phase I = Early Bronze Age IB.

study by O. al-Ghul and L. Khoury).

“The White Building” will be further exposed during the spring 1997 excavation season.

### The White Building of Tall Abū al-Kharaz (Helena Ingemarsdotter)

During the spring 1996 season of excavation, on the summit of Tell Abū al-Kharaz, parts of a monumental building were exposed. Its interesting architecture, possible function, and date will briefly be discussed here (see also Fischer 1996a and b, and 1997).

Traces of this building were discovered

earlier during a survey in 1989 (Fischer 1991: 69). The writer of this article had the opportunity to follow the exposure of the construction day by day, from the 18th of March to the 21st of April 1996.

### The White Building

The flat summit of Tall Abū al-Kharaz, where this structure is located, measures approximately 120 m to the east-west and 90 m to the north-south. The dimensions of the building exposed so far are 10.60 x 11.70 m. The axes of the building are oriented strictly north-south and east-west. It is constructed of ashlar masonry and of rubble

TELL ABU AL-KHARAZ  
SWEDISH JORDAN EXPEDITION 1996

AREA 10

UNEXCAVATED

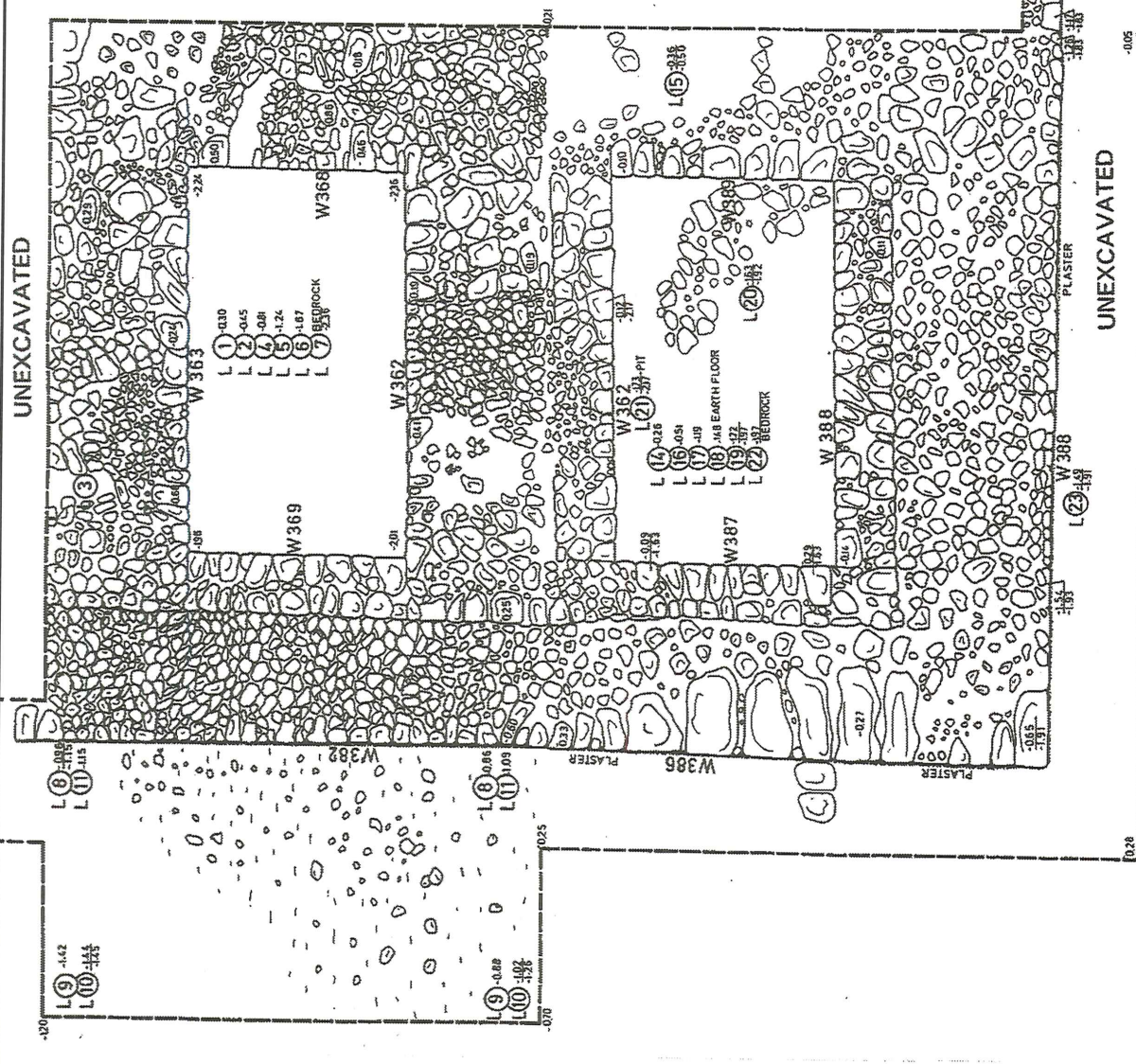

UNEXCAVATED

9. Area 10: "The White Building".

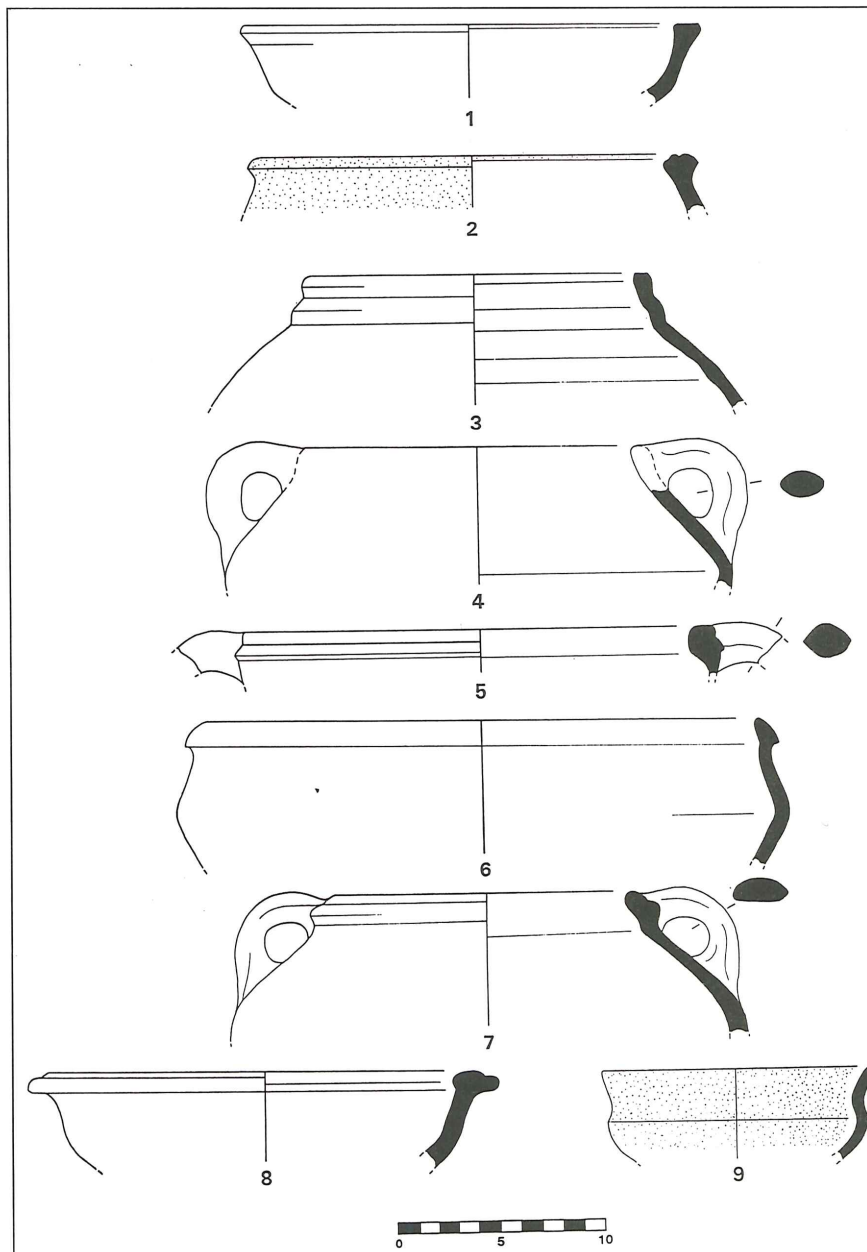

1. XXXIII1L18-3, bowl, wheel-made, medium-hard fired, light grey clay, fine, self slip.
2. XXXIII1L18-5, bowl, wheel-made, hard-fired, yellowish-brown clay, light grey core, medium-fine, a few large inclusions, self slip.
3. XXXIII1L18-1, cooking pot, wheel-made, hard-fired, greyish-brown clay, thick grey core, coarse, mainly large white inclusions, self slip.
4. XXXIII1L18-2, cooking pot, wheel-made, hard-fired, reddish-brown clay, thick grey core, coarse, mainly white inclusions, self slip.
5. XXXIII2L19-5, cooking pot, wheel-made, hard-fired, reddish-brown clay, coarse, mainly white inclusions, self slip.
6. XXXIII2L21-1, cooking pot, wheel-made, hard-fired, reddish-brown clay, coarse, mainly white, inclusions, self slip.
7. XXXIII2L21-4, carinate bowl, wheel-made, medium-soft fired, light brown clay, medium-fine, mainly white inclusions, yellowish-brown slip.
8. XXXIII2L21-2, bowl, wheel-made, medium-hard fired, light brown clay, medium-coarse, mainly grey inclusions.
9. XXXIII2L21-3, cooking pot, wheel-made, hard-fired, yellowish-brown clay, thick dark grey core, coarse, mainly white inclusions, self slip.

10. Iron Age pottery from the "White Building".

stone. The building material is locally quarried limestone. Mortar was not used. The walls are approximately 1.50–2 m wide and neatly constructed with relatively flat surfaces. Well-preserved white plaster of lime and sand covers the western and southern walls, which are the only outer walls exposed so far.

Two rooms have so far been exposed. A considerable amount of fallen stone were discovered inside the rooms, very likely deriving from the collapsed upper floor(s).

The southern room had an approximately 1 m thick layer of fallen stones mixed with a small amount of mainly Iron Age sherds. The northern room measures 2.30 x 3.90 m, and the southern room 2.30 x 3.80 m. The inner walls of the northern room are placed directly on bedrock, while the inner western and southern walls of the southern room are built on fill. The walls of the southern room consist of 6 to 7 courses of stone. The width of the wall separating the rooms is 2 m. The northern room has disturbances in the east-

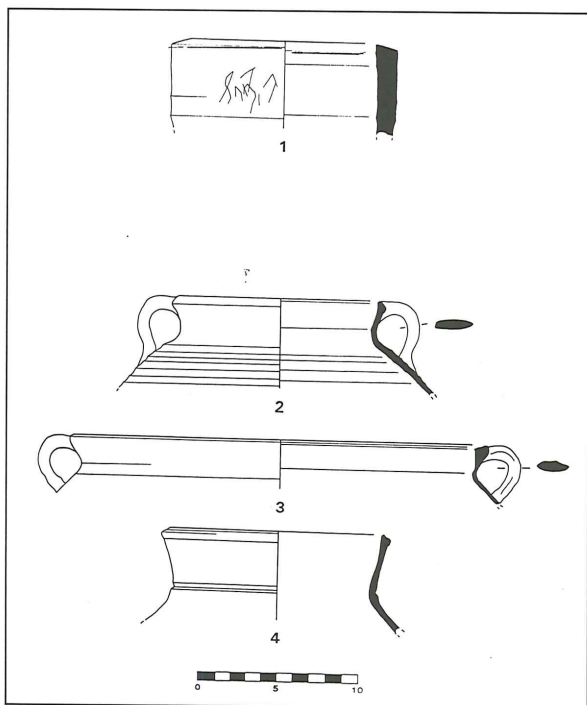

11. Ostrakon from the “White Building”, northern room (1). Rims from outside the southern wall of the structure (2-4).
1. XXXIL5-1, jar, wheel-made, hard-fired, yellowish-brown clay, coarse, mainly grey inclusions, self slip, inscribed.
  2. XXXIII1L16-2, cooking pot?, ripped ware, wheel-made, hard-fired, brownish red clay, medium-fine, grey and white inclusions, dark brown slip.
  3. XXXIII1L23-1, cooking pot?, wheel-made, hard-fired, brownish-red clay, fine, self slip.
  4. XXXIII1L23-2, jar, wheel-made, hard-fired, light brown clay, medium-fine, white inclusions, limy slip on outside.

ern and northern walls, which have not been satisfactorily explained yet.

Since there was not enough time to excavate the whole structure, the excavations were focused on the exposure of the southern and western walls. Outside the western wall, there was an abundance of fallen stone, very likely from the collapsed upper wall. Underneath these stones, a stone pavement can be traced. This pavement is attached to the western wall. The plaster that is covering the wall goes underneath the pavement, indicating that the pavement is of a later date. Late Roman sherds could be associated with the stone pavement.

The lower courses of the southern wall consist of large blocks of stone. The upper courses consist of smaller stones. The wall is built of one to three courses of rectangular stones, with plaster. This wall rests in a foundation trench cut into the underlying bedrock. Many fallen stones were detected outside the wall, to the south.

It is anticipated that there are at least two more rooms to the east of the two exposed western rooms.

### Discussion

The function of this building is debatable, especially considering the early stage of excavation. It could have been a fortress, a palace or an administrative building, but it may also have had a combined function. We do not know at the moment whether it is a single building or a part of a building complex. It should be remembered that in its vicinity, other structures were found during the survey of 1989.

The orientation of the building in a north-south to east-west direction is interesting. Iron Age and Late Bronze structures within the city of Tall Abū al-Kharaz are usually aligned on a south-east/north-west axis, but Early Bronze structures are commonly on a north-south/east-west axis (Fischer 1996b: 32).

The rooms may have been used as storage rooms or basements. There are towers associated with rooms in Jordan (Koucky 1987b: 64). The walls are built directly on bedrock in foundation trenches, possibly to make them less vulnerable to earthquakes. It has been demonstrated by a number of examples that buildings built on bedrock resist earthquake damage much better than those built on fill or sediments (Koucky 1987a: 35).

The heavy construction of the building favours the fortress theory. A fortress should contain a tower. There are some examples of Iron Age watch-towers in Jordan, for example at ar-Rumayl, south-east of the

Dead Sea (16 x 9 m; de Montlivault-Villeneuve 1989: 492), and as-Sade, between the Dead Sea and the Red Sea (with a 9 m long foundation of heavily plastered ashlar; Lindner 1989: 506), the Plateau Fort, near the Wādī al-Kufrayn in the Jordan Valley (13.50 x 14.50 m), and at Rujm al-Makhaizin, north-east of 'Ammān (12.20 x 12.25 m; Prag *et al.* 1996: 44, 47). The towers are considered to be fairly large, and are built of trimmed megalithic stones without mortar. The towers are usually placed on high elevations near a wadi (Koucky 1987b: 64). The Iron Age fortress of al-Lahūn east of the Dead Sea has plastered western and southern walls to protect them from the rain and the wind blowing from the Dead Sea Valley (Homès-Fredericq 1989: 354). As regards the white building of Tall Abū al-Kharaz, it is not yet known whether the northern and eastern walls are plastered. In the Iron Age period, there was a system of border fortresses on both sides of the Jordan River (Prag *et al.* 1996: 48), and perhaps our example belongs to that defence system.

During the Late Roman Age, towers were common in central and north-eastern Jordan. Examples of Roman occupation are buildings at al-Lajjūn, east of the Dead Sea (Parker 1989:360), Tall as-Sa'idiyya, in the Jordan Valley (9.25 x 10.40 m; Tubb 1989: 541), as-Samrā', 50 km north-east of 'Ammān (Humbert 1989: 555), and Quṣūr Bshayr, east of the Dead Sea (Koucky 1987b: 66). Watch-towers from the Iron Age or the Nabataean period were re-occupied by the Late Romans to form a network of observation posts within sight of one another (Parker 1984: 36). They make part of the *Limes Arabicus*, which was the Roman frontier east of the Dead Sea between AD 300 and 550. Examples of sites containing Iron Age fortresses with towers that have been reused in Late Roman and even Early Byzantine period are found at Qaṣr Abū al-Kharaz and Qaṣr al-Al (Prag *et al.* 1996: 59). Late Roman masonry in gen-

eral means constructions of locally quarried limestone and chert (Parker 1989: 363). The towers were usually almost square, with side dimensions from 10-12 m.

An ostrakon with a possible Aramaic inscription found in the north-western room suggests a dating within the 1st millennium BC (Fig. 11:1; see the excavation report above, and Fischer 1996a: 33). The pottery collection from inside the building also suggests a date within the Iron Age period (Fig. 10). However, outside the building, large amounts of Late Roman sherds were found, which points to reuse in Late Roman time (Fig. 11). It is likely that the Romans did not construct this building, as they generally used mortar in their building programmes, even though there are examples of Roman structures with no mortar at all (Parker 1987: 174). One example is at Qaṣr al-'Uwaynid (Kennedy 1982: 121). Furthermore, the Romans did not usually build their towers on high elevations, but in major wadis and guarded crossings (Koucky 1987b: 66).

Ashlar masonry was frequent in the Bronze Age, in Cyprus and in other regions of the Eastern Mediterranean. Ashlar masonry in general means structures of wrought blocks with approach. The blocks do not always reach the ideal of rectangular visible face when they are put in place. There is a more limited definition of ashlar masonry, applied to architecture of later times, which says that true ashlar blocks should have all faces worked to a perfectly rectangular shape, usually of uniform size and filling the thickness of the wall (Hult 1983: 1-2). Examples of so-called coursed ashlar masonry from the Bronze Age are found in nearby regions such as Cisjordan and the northern Levant. Coursed ashlar masonry means that the lower part of the building is ashlar and the upper part is rubble (Hult 1983: 30). It is not likely that the building, which partly consists of coursed ashlar masonry, is later than the Iron Age

period, as the ashlar blocks are laid irregularly and the faces are not worked to perfectly rectangular shapes.

### Pottery

The sherds collected from the loci belonging to the interior rooms are mainly from the Iron Age period. The few discovered Late Bronze Age sherds are probable remainders of a Late Bronze Age building, which maybe was originally erected on this spot.

### Concluding Remarks

The most likely theory so far is that the building belongs to the Iron Age. Its closest parallel is the Iron Age Plateau Fort, near Wādī al-Kafrayn in the southern Jordan Valley. Late Roman sherds collected do not imply a military occupation of the site, even if this may have been the case.

One difficulty, as pointed out by Dornemann (1983: 124) when summarizing the reported fortifications in Transjordan in the Iron Age, is that it is not possible to distinguish between Early Bronze Age, Late Bronze Age, Iron Age, Roman, or Byzantine megalithic structures. At the present stage of the excavation, neither a definite date of the Tall Abū al-Kharaz building nor a definite explanation of its function can be given. However, the spring 1997 excavation will provide more information.

### Acknowledgements

I would like to express my great gratitude to TRH Prince Raad Zeid and Princess Majda Raad Zeid for their interest and support of *SwedJordEx*. I also thank the Department of Antiquities and its Director-General, Dr Ghazi Bisheh, whose generous assistance included the loan of one of the Department's vehicles, which was vital in enabling the excavations to be carried out successfully. I am in addition indebted to Zeidan Kafafi and the administration of the Yarmouk University for permission to rent the Dayr 'Allā Dig House in 1995, and to Basil Hennessy and Dr Stephen Bourke for permission to rent the Pella Dig House. Finally I wish to thank all the team members for their sincere interest and hard work, which greatly contributed to the successful execution of the excavations.

Financial support was given by the former Swedish Board for Investment and Technical Support (BITS), now SIDA, and the private company Polylys Com, also of Gothenburg.

Peter M. Fischer  
Melena lugemarsdotter  
Göteborg University  
Dörjeskärsgratan 37  
S-421 60 Västra Frölunda  
Sweden

## Bibliography

- Dornemann, R. H.  
 1983 *The Archaeology of the Transjordan in the Bronze and Iron Ages*. Milwaukee.
- Fischer, P.M.  
 1991 Tall Abū al-Kharaz. The Swedish Jordan Expedition 1989. First Season Preliminary Report from Trial Soundings. *ADAJ* 35: 67-104.  
 1993 Tall Abū al-Kharaz. The Swedish Jordan Expedition 1991. Second Season Preliminary Excavation Report. *ADAJ* 37: 279-306.  
 1994 Tall Abū al-Kharaz. The Swedish Jordan Expedition 1992. Third Season Preliminary Excavation Report. *ADAJ* 38: 127-145.  
 1995 Tall Abū al-Kharaz. The Swedish Jordan Expedition 1993. Fourth Season Preliminary Excavation Report. *ADAJ* 39: 93-119.  
 1996 Tall Abū al-Kharaz. The Swedish Jordan Expedition 1994. Fifth Season Preliminary Excavation Report. *ADAJ* 40: 101-110.  
 1996a Svenska Jordaniexpeditionen 1989-1996. Tall Abū al-Kharaz i det bibliska landskapet Gilead. *Medusa*: 27-34.  
 1996b The Mound of the Father of the Beads: Excavating in the Jordan Valley. *Minerva* 7: 30-33.  
 1997 Arkeologisk expedition i Jordanien. *Populär Arkeologi* 15: 1, 35-38.
- Homès-Fredericq, D.  
 1989 Lehun (el/Khirbet el). Pp. 349-359 in D. Homès-Fredericq and J. B. Hennessy (eds), *Archaeology of Jordan*. *Akkadica* Suppl. VIII. Field Report II2..
- Hult, G.  
 1983 *Bronze Age Ashlar Masonry in the Eastern Mediterranean. Cyprus, Ugarit, and Neighbouring regions*. *SIMA* 66. Göteborg.
- Humbert, J-B.  
 1989 Samra (Khirbet el/Qala'at es-Samra/Khirbet es-Saoudain. Pp. 554-557 in D. Homès Fredericq and J. B. Hennessy (eds), *Archaeology of Jordan*. *Akkadica* Suppl. VIII. Field Reports II2. 554-557.
- Kennedy, D. L.  
 1982 *Archaeological Explorations on the Roman Frontier in North-East Jordan*. BAR Int. Ser. 134. Oxford.
- Koucky, F. L.  
 1987a The Regional Environment. Pp. 11-40 in S.T. Parker (ed), *The Roman Frontier in Central Jordan*. BAR Int. Ser. 340. Oxford.
- Koucky, F. L.  
 1987b Survey of the Limes Zone. Pp. 41-106 in S.T. Parker (ed.), *The Roman Frontier in Central Jordan*. BAR Int. Ser. 340.
- Lindner, M.  
 1989 Sade (el/es Sade). Pp. 505-511 in D. Homès-Fredericq and J. B. Hennessy (eds), *Archaeology of Jordan*. *Akkadica* Suppl. VIII. Field Reports II2.
- de Montlivault-Villeneuve, E.  
 1989 Rumeil (el). Pp. 491-494. in D. Homès-Fredericq and J. B. Hennessy (eds.), *Archaeology of Jordan*. *Akkadica* Suppl. VIII. Field Reports II2.
- Parker, S. T.  
 1984 Exploring the Roman Frontier in Jordan. *Archaeology* 5: 33-39.

- Parker, S. T.  
1989 Lejjun. Pp. 359-367 in D. Homès-Fredericq and J. B. Hennessy (eds), *Archaeology of Jordan. Akkadica Suppl. VIII. Field Reports II2*.
- Prag, K. and Barnes, H.  
1996 Three fortresses on the Wadi Kafrain, Jordan. *Levant* 28: 41-61.
- Thompson, H.O.  
1971 Iron Age Cosmetic Palettes. *ADAJ* 16: 61-70.
- Tubb, J. N.  
1989 Sa'idiyeh (Tall el). Pp. 521-542 in D. Homès-Fredericq and J.B. Hennessy (eds), *Archaeology of Jordan. Akkadica Suppl. VIII. Field Reports II2*.
- Wentworth, C.K.  
1922 A Scale of Grade and Class Terms for Clastic Sediments, *Journal of Geology* 30: 377-392.  
1933 Fundamental Limits to the Sizes of Clastic Grains, *Science* 77: 633-634.