

# The Danish-German Jarash Northwest Quarter Project 2013 Preliminary Registration Report

*Achim Lichtenberger, Rubina Raja and Annette Højen Sørensen*

## Introduction

The present report highlights a relevant number of objects from the 2013 campaign.<sup>1</sup> The first part of the report will be devoted to the general characteristics of the five trenches, the pottery and small finds from these trenches as well as give a summary of the general find assemblages of the 2013 campaign. Included at the end of this report are two shorter reports on the glass finds from the 2012 and 2013 campaigns by Holger Schwarzer and the find coins from the 2012 and 2013 campaigns by Stefan Riedel.

During the six weeks of campaign the registration registered a total of about 120.000 objects. This corresponded to around the same amount as during the 2012 campaign. Of these a total amount of 1.923 objects were basis-registered (described, drawn, and photographed) and furthermore several finds were conserved. As during the 2012 campaign all finds were processed and this registration report thus represents the entire corpus of objects excavated during the 2013 campaign. The catalogue which contains 180 objects discusses the general features within the assemblages as well as some more characteristic objects. Emphasis is on the installations in trench D described below and in the field report by Kalaitzoglou, Lichtenberger and Raja in this volume due to the nature of the

context and the finds from the trench.

The object groups found during the 2013 campaign are similar to the 2012 campaign object groups in number and general shapes. However, from the 2013 campaign a much better representation of Roman period objects is observed. A small amount of pottery, which could be taken to be Abbasid, has come to light. However, due to the stratigraphical lack of Abbasid evidence these pieces probably need to be attributed to the Late Umayyad phase. This conclusion shows that our detailed stratigraphic observations contribute to a better chronological understanding of the development of pottery in the Early Islamic periods as well as the dynamics concerning continuity and change between the Umayyad and Abbasid periods.

## Trenches

On the basis of the overall so-called “total registration”, which is the initial sorting process applied to the material, an attempt has been made to quantify certain ware groups in the material from the 2013 campaign.<sup>2</sup> The statistic is presented below in tables 1-5. The distinct groups of Ayyubid/Mamluk painted and unpainted Islamic Glazed wares, Green Ware, Grey Ware, Reddish/Red-brown Ware, Jerash Bowls, Orange Ware, Roman Red Slipped

---

1. Acknowledgements: We wish to thank John Lund and Jakob Munk Højte for the valuable input on the red slipped pottery, Frauke Kenkel for discussions and input on pottery wares and Ingemann Schnetler, Claus Heilmann-Clausen, and Walter Friedrich for input on fossils and geology. Christoph Eger gave valuable advice on the metal finds. Furthermore we would like to thank the DFG (Deutsche Forschungsgemeinschaft)

as well as the Carlsberg Foundation and the H. P. Hjerl Hansen Mindefondet for Dansk Palæstinaforskning for their financial support for the project.

2. During the last days of excavation it was however decided to dump un-counted material after washing in order not to leave behind a backlog. Only material from already well-known evidences was dumped without sorting.

Wares (note that the ESA, ARS and other local and imported wares are grouped together) and Hellenistic Black Glazed have been selected in this quantifying process for presentation in the catalogue. Buff Ware and other Abbasid-Ayyubid wares (which will be elaborated upon in the final publication) have been grouped together in the tables presented below. With the reservation for possible counting and calculation errors a table showing the percentages of these ware groups in the total amount of objects has been made separately for each of the trenches (D-H) below.

**General Characteristics of Trench D**

The total number of pottery<sup>3</sup> found in Trench D is 4.933. Of these 3.45% were kept. The number of registered objects is rather high from this trench which is due to the high amount of well-preserved objects and the intact installations in the trench (cf. below and field report, this volume).

The larger part of the pottery material which is not represented by **Table 1** was made up by various, yet undescribed, coarse and ribbed plain wares, in total counting 3058 pieces. All types of fine wares are listed in the table and the scarcity of these fine wares, apart from the Middle Islamic “Hand-Made Geometrically-Painted Ware” (HMGPW)<sup>4</sup> is noteworthy. As the south room of the trench belonged to a Mamluk house the relatively high amount of Ayyubid/Mamluk finds is not surprising.

The material from the uppermost evidences of trench D is a mix of Ayyubid/Mamluk pottery of

the HMGPW and unpainted Ayyubid/Mamluk and earlier wares. The following evidences have yielded Ayyubid/Mamluk wares: 0, 1, 2, 7, 8, 9, 10, 12, 13, 24, 25, 29 and 32.

Apart from the intact installations in the North Room, described below, the evidences in the trench are mostly mixed and it was also possible to make a join between the trenches as an Ayyubid/Mamluk base in two pieces was found fragmented respectively in trench D evidence 9 and trench E evidence 17 (cat. no. 37).

*North Room*

Trench D has yielded a room with intact installations – the North Room (cf. field report this volume) as well as a much more destroyed room to the south.

Of specific interest in relation to the North Room is the fact that Ayyubid/Mamluk finds have not been detected below evidence 13; neither have any identified Abbasid objects. In evidence 13 (a fill layer above the intact installations) a small amount of wall plaster was found and some Grey Ware which likewise carried traces of plaster.

The date of the installations in the North Room, the oven/tabun and the basin is judging by the fill Byzantine or perhaps early Umayyad as indicated by a Jerash Lamp handle (cat. no. 52) found in evidence 16 (the tabun). The oven/tabun itself was constructed from a hand-made pithos with an attached (wheel made?) rim (cf. also registration report) placed up-side-down. The few sherds from the pithos which was examined in the registration seem to be of a handmade

**Table 1**

Ayyubid/Mamluk HMGPW	Ayyubid/Mamluk Undecorated	Abbasid-Ayyubid	Islamic Glazed	Grey Ware (Byz-Uma)	Reddish /Red Brown ware	Jerash Bowls	Red Slipped Fine ware (Rom-Byz)	Unspecified (mainly coarse and ribbed wares)
2.62%	Max. 5.43%	1.05%	0.06%	20.54%	8.05%	0.08%	0.18%	Max. 61.99%

3. Excluded from this total number are bricks, tiles, water pipes, suspensura, and terracotta figurines.

4. Johns (1998).

(grey?) ware pithos. The fragments analysed in the process of registration were undecorated. However a grey ware sherd from a hand-made storage jar with combed decoration was located. The coins, glass, the key and the pottery found in and around the North Room installations (ev. 16-19 cat. nos. 175-177, 166, 132, 23, 65, 84, 142, 144) date to the Roman-Byzantine-Umayyad periods. There is no evidence which stems from earlier periods. The large blade (cat. no. 133), which was found against the wall behind the tabun has a parallel from Ein Boqeq and it does seem reasonable to date it contemporary with the use of the installations in the room due to its position on the floor of the room. The finds from the North Room thus tentatively indicate a use not later than the Umayyad period.

### South Room

In the south room of trench D Ayyubid/Mamluk undecorated pottery was found in evidences which continued until bedrock (evidence 32 being the lowest evidence level). In the lower strata it mainly consisted of unpainted handmade body fragments and was mixed with Early Bronze Age (cat. no. 180) and later material. The torso of an Artemis Rospigliosi type marble

sculpture, cut in the shape of a wall stone, was found in the collapse from the wall. It had formerly been used as a stone in the wall in the room along. It was found along side Ayyubid-Mamluk material and painted wall plaster (cat. nos. 146, 34-38, 40, 117-118, 148-149).

Primarily in evidences 10 and 29 fragments of wall painting were uncovered. The decoration consisted mainly of parallel bands of different colours (red, yellow, black, blue, and pink) and varying width. The quantity of wall plaster was rather high in evidences 10 and 29 and some of these fragments were painted. Ayyubid/Mamluk pottery from evidences 10 and 29 were joined (cat. no. 36) and it is most likely that the plastered and painted fragments from the two evidences belong to the same building phase (cf. field report this volume). Mamluk wall paintings are in general scarce in the Levant.<sup>5</sup>The paintings uncovered in trench D are very fragmentary and it has not been possible to join any fragments or distinguish any ornamental decoration. A few fragments do, however, attest to lines in different colours and the use of string impressions, which are normally used as guidelines in the painting process.

Evidence 30 held remains of an older plastered

---

5. The best preserved Islamic paintings are the famous Umayyad Qusayr Amra paintings from Jordan (Ettinghausen (1962). Recently fragments of Umayyad paintings from Gabal Says (Bloch (2011) have been published and the elaborate floor and mural paintings from shahr-e Gur in Iran are also well known (CAIS – the Circle of Iranian Studies: <http://www.cais-soas.com/News/2006/February2006/19-02.htm>). In Syria the Umayyad palace of Qasr el-Heir el Gharbi (Schlumberger (1986) has yielded figurative wall-paintings. Later examples of Arab paintings do exist, especially the paintings in the palace at Samarra, Iraq has yielded rich figurative decorations from the Abbasid period. (Ettinghausen (1962). In the Cappella Palatina of Palermo, Sicily, dated to the mid 12th century ceiling paintings are very well preserved (Ettinghausen, (1962), pp. 44-50; Ettinghausen (1942); Racioppi (2014): [http://www.discoverislimicart.org/database\\_item.php?id=monument;ISL;it;Mon01;10;en and cp](http://www.discoverislimicart.org/database_item.php?id=monument;ISL;it;Mon01;10;en and cp)). The technique used for these are however tempera on wood. The paintings of Cappella Palatina were most probably executed by a

(Fatimid?) Arab painter by order of the Norman ruler, Roger II. The city of Cairo in Egypt has likewise yielded figurative paintings from the rule of the Fatimid Caliphate e.g. in a hammam in Cairo (Cruikshank Dodd (1997/98), p. 270, fig. 17; Ettinghausen (1942), fig. 23-24). However, during the Abbasid, Fatimid, Ayyubid and Mamluk periods figurative paintings are primarily known as miniature paintings used as book illustrations (Cf. Ettinghausen (1942); Ettinghausen (1962)). According to Watson one of the churches in Pella was decorated with paintings (Watson (2008), p. 459) and the monograph by Cruikshank Dodd concerned with the medieval painting primarily from the Crusader Period during the reign of the Mamluks likewise emphasise the Medieval Christian church paintings (Cruikshank Dodd (2004); cf. also her 1997/98 article for the Christian Paintings in the Lebanon). Arab architectural decoration was generally focused on e.g. calligraphy and the ornamentations in e.g. the *Beveled Style* and other nonfigurative ornamental styles. This pattern, however, does not exclude the existence of not non-figurative murals.

floor (cf. registration report in this volume). Fragments of plaster were also uncovered in evidence 7. These were, however, thick and unpainted and may also stem from a plastered floor.

Towards the lower parts of the south room just above bedrock a rather homogenous fill of unpainted, thick walled, handmade vessel fragments were found. The fill in evidence 25 was mixed with a coin, a few glass fragments and a few wheel made ceramic fragments. The material mostly consisted of undiagnostic fragments, but a date in the later medieval period seems reasonable for this context. For this reason it is included in the relatively high percentage of undecorated Ayyubid/Mamluk handmade pottery in the table above.

**Trench E**

Trench E yielded a large amount of pottery; in total 38.199 sherds were found but only 0.61% was kept, a total of 234. The objects represented in **Table 2** are, as above in **Table 1** concerning trench D, chronological markers – especially fine wares and the remaining group of mainly plain and coarse wares are grouped together and shown in the last column. A similar approach has been applied to all the tables. The amount of fine ware is even scarcer here than in Trench D and the majority of the material consisted of ribbed plain wares primarily of the Byzantine-Umayyad period. One part of the trench seems to have been filled with the same kind of dump as seen in trench B during the 2012 campaign that is a Byzantine-Umayyad fill consisting primarily of ribbed plain wares (see Lichtenberger, Raja

and Sørensen in *ADAJ 57*.

Ayyubid/Mamluk pottery has been located in the following evidences: 1, 7, 8, 10, 14, 17, 32 and 49 – most evidences are located in the upper layers of the trench and the amount of Ayyubid/Mamluk pottery is rather low – and might in some instances be regarded as intrusions. The evidences yielding most Ayyubid/Mamluk is evidence 8, where all the material found was very worn, evidence 10 in which much older material is mixed and in evidence 17 where a painted Ayyubid/Mamluk piece of a base was found, which joined with a piece from evidence 9 in trench D (cat. no. 37) (cf. above).

The evidences surrounding the intact water-pipe described in the field report (this volume) running north-south will be AMS (accelerator mass spectrometry) dated and results are pending. However, the ceramic evidence might give a preliminary indication of the construction date. In evidence 50 below the water pipe in sector a, a worn rim of an Eastern Sigillata A ware bowl was found, which point to the piece being older and thus not contemporary with the fill. In evidence 44 above the water pipe no fine wares were found and only very few diagnostic sherds were found. However, the evidence did not contain any Grey Ware or later wares but contained an Orange Ware rim which points to a date in the Roman-Byzantine period. Furthermore cooking pot rims of a Late Roman date with a ridge on top of the rim were also found.<sup>6</sup> In addition some ribbed plain wares were located in this evidence. Evidence 47 covered and ran against the bedrock and

**Table 2**

Ayyubid/Mamluk HMGPW	Ayyubid/Mamluk Unpainted	Abbasid/Ayyubid	Islamic Glazed	Grey Ware (Byz-Uma)	Reddish /Red Brown ware	Jerash Bowls	Red Slipped Fine ware (Rom-Byz)	Unspecified (mainly coarse and ribbed wares)
0.14%	0.04%	0.03%	0.005%	11.16%	0.57%	0.33%	0.18%	87.54%

6. Compare with Hisban, Gerber (2012), fig. 3.31

and the present catalogue no. 85.

did not contain any Grey Ware, only one small piece of fine ware, handmade storage jars and two pinched handles which point to a Roman or Byzantine date. In sum, the evidences below and just above the water pipe suggest a date before the production of Grey Ware in the Roman or the early Byzantine period.

The general picture, however, emerging from the trench is a mixture of mainly Byzantine-Umayyad material with a few objects of older and younger date. The lower parts of the trench around the water pipe are, as described, somewhat earlier.

### **Trench F**

Trench F was, as described in the field report (this volume) a long trial trench stretching across the vast cistern as well as a large area around the cave to the west. The total amount of pottery counted was 17.683. Of these 1.07% was kept a total of 190 fragments. Considering the large area in the cistern covered by this trench the number of finds is considerably lower than in the other trenches.

Grey Ware is prominent in trench F whereas later Islamic wares are almost non-existent. Grey Ware was produced in the Byzantine-Umayyad periods in Jerash and seems to be scarce before and after. The remaining part of the material from the trench consists of various ribbed household and storage wares.

One evidence, 17, consisted primarily of Roman fine and plain ware shapes (cat. nos. 4, 107), but with a few possibly later finds. This

will, however, need further investigation in order to give a firm conclusion.

The clearings in sector i yielded a fill typical of the Byzantine-Umayyad period consisting mainly of ribbed wares. The Grey Ware was prominent.

Significant and worth noting in trench F is the nearly complete absence of Ayyubid/Mamluk HMGPW. This type of pottery was only attested once, in evidence 15 where one piece of geometric painted ware was found. The context of evidence 15 is mixed and the sherd may be counted as an intrusion.

The general picture emerging from the study of the objects from the cistern is that it primarily consisted of Byzantine-Umayyad fills of the very characteristic wares of the period – especially the Grey and the Reddish/Red Brown ware.

### **Trench G**

257 pottery fragments, i.e. 0.6% of the total amount of 43.756 ceramic finds from this trench was kept.

The ceramic material from trench G is within the topsoil evidences characterised by worn and broken pieces of mostly locally produced Grey and ribbed plain household wares. Especially the upper evidences in the trench have yielded a mixture of Roman-Byzantine-Umayyad material. From evidence 12 and below the occurrences of Grey Ware is scarce if present at all. Intrusions of Umayyad pottery comparable with pottery from Pella and Ayyubid/Mamluk

**Table 3**

Ayyubid/Mamluk HMGPW	Green Ware	Orange Ware	Abbasid/ Ayyubid	Grey Ware	Reddish/ Red Brown ware	Jerash Bowls	Red Slipped Fine ware (Rom-Byz)	Unspecified (mainly coarse and ribbed wares)
0.006%	0.01%	0.01%	0.02%	27.12%	2.77%	0.4%	0.15%	69.51%

**Table 4**

Ayybid/Mamluk HMGPW	Ayyubid/Mamluk undecorated	Abbassid/Ayyubid	Green Ware	Orange Ware	Grey Ware	Reddish/Red Brown ware	Jerash Bowls	Red slipped fine ware (Rom-Byz)	Unspecified (mainly coarse and ribbed wares)
0.005%	0.07%	0.03%	0.06%	Min. 0.12%	11.23%	0.27%	0.12%	0.35%	87.7%

pottery are found in evidence 28.<sup>7</sup> The main body of material from evidence 12 and below thus seems to be of Roman-Byzantine date but with younger intrusions. The amount of Grey Ware is remarkably lower than in trenches D and F but the amount corresponds well with the material evidence of the neighbouring trench H and in trench E.

In trench G Ayyubid/Mamluk pottery was found in evidences 12, 20, 23, 28, 33 and possibly in 30. The number of sherds is very low and consists primarily of the unpainted handmade wares as indicated in **Table 4**.

#### **Trench H**

A total of 10,187 ceramic fragments were registered from trench H. Of these 1.1% was kept which is a total of 112 fragments. As in the tables 1-4 the total amount of sherds are represented.

In trench H a fair amount of the various Roman wares (plain household wares and fine wares (ESA, LRC)) located this year was found in e.g. evidences 13 and 14 mixed with Byzantine and Umayyad material as well as few Abbassid, Hellenistic (cat. nos. 1-2) and Nabataean (cat. no. 3) fragments. Worth noting is the amount of Roman fine wares found in the trench which is just below 1% of the total amount of pottery from the trench. Apart from the HMGPW in trench D these Roman/Byzantine red slipped wares make up the largest quantity of fine wares found in any of the trenches during the 2013

campaign. The Roman activity on the hill is thus quite apparent on the northern slope within the ceramic and small find record. An imported stone mug fragment probably from the first century AD is one of the more conspicuous finds from the trench (cat. no. 137). Such vessels were found in settlements with Jewish population and occur in some places in Jordan<sup>8</sup>.

In trench H Ayyubid/Mamluk unpainted pottery was found in small quantities in the evidences 5, 8, 9, 13, 14 and 16 but is not significant in the general picture of the trench.

#### **Finds**

The variety of finds from the 2013 campaign attests to everyday life and production in the Northwest Quarter in Jerash during several historical periods – from the Hellenistic to the present day with the possible appearance of a few Bronze Age ceramic fragments (cat. no. 180). Local production is attested through pottery wasters (cat. no. 150), a mould (cat. no. 128) and fragmentary crucibles (cat. no. 151). Spindle whorls (cat. nos. 143-144) were also found in a small number, but only one possible loom weight of a conical shape has been recovered from the site (cat. no. 145) (cf. below for a presentation of the glass and coin material).

The animal bones from the campaign were found in most evidences throughout the Northwest Quarter and represent among other horses, sheep, cows and pigs – i.e. larger

7. Smith (1973), pl. 91.C no. 1112.

8. Most of the vessels are from the Peraia; they are attested at Mount Nebo (Saller 1967, 41-43), in Khirbat Umm ad-Dananir (McGovern 1989, 127), Machaerus

(Loffreda 1996, 116f. Fig. 53), Callirrhoe (Clamer 1997, Tf. 14; Strobel and Wimmer 2003, Tf. 13f.) and at the Baptism Site (Abu Shmeis and Waheeb, 2002, 565).

**Table 5**

Ayyubid/ Mamluk unpainted	Abbasid/ Ayyubid	Green Ware	Grey Ware	Reddish/Red Brown ware	Jerash Bowls	Red slipped fine ware (Rom-Byz)	Hellenistic Black Glazed	Unspecified (mainly coarse and ribbed wares)
0.15%	0.1%	0.28%	11.64%	0.4%	0.05%	0.9%	0.03%	86.45%

domesticated animals but also a fair amount of bird bones were recovered. The bones were often broken and found as fill in the various evidences but almost none showed traces of heating or cooking.

The iron objects recovered in the 2013 campaign were all quite corroded. They were mostly nails or smaller fragments of undiagnosed objects. The North Room of trench D yielded the find of a Roman iron key and a rather large knife blade which once was wrapped in textile and held in a leather scabbard (cat. nos. 132-133).

Within the amount of material from the campaign a variety of marine fossils were likewise recovered. Some of these might stem from the Parathetys ocean during the Tertiary period and will be studied in more detail for the final publication of the Northwest Quarter. Only one fossil, a Steinkern of a large gastropod, has been catalogued as it was found built into a wall in trench D and thus with certainty integrated in the human activities on the hill (cat.no. 152).

Many other find groups were likewise present in the excavation like architectural elements (cat. no. 147), bricks (cat. no. 119-120), tiles (cat. no. 121-122), stone vessels (cat. nos. 137), grinders (cat. nos. 140-142), mortars (cat. nos. 138-139), terracotta figurines (cat. nos. 124-127), one small gold piece (cat. nos. 136), one amber bead and a large fragment of a marble sculpture (cat. no. 146). The objects date to various periods. Most of these find groups are represented in the catalogue, however, as most contexts are mixed the selection of objects have been made to show the chronological, typological and material variety of the finds from the Northwest Quarter.

### **General Observations**

Grey Ware pottery is the most characteristic ware which has been found in considerable amounts across the entire hill. Other plain ribbed household wares are also quite common and the general trend is the use of the well known locally produced pottery at least in the Roman, Byzantine and Umayyad periods. It would, however, be desirable to conduct more research on the other plain wares which are, like the Grey Ware, most likely of local manufacture and which represent a large amount of among other shapes jugs, jars and amphorae and which to a large extent are ribbed.

During the 2012 campaign all three trenches were placed on top of the hill and the amount of Roman slipped and unslipped pottery was quite low. In terms of locating more remains of the Roman period it proved successful to move some of the excavation activities to the slopes of the hill. Especially the northern slope yielded a relatively large amount of Roman pottery. The Roman unslipped household wares may have been locally produced, but here more comparative material is needed and local kilns from the period should also be investigated. The few Hellenistic objects from the campaign were also primarily found on the north slope of the hill (glass and pottery, cat. nos. 1-2, 153-154).

The Ayyubid/Mamluk presence on the hill is most apparent on its highest points within the "Mamluk hamlet"<sup>9</sup> and not on the slopes of the hill. The virtually absence of Islamic glazed wares is striking and certainly does not point towards a rich settlement at the site. Nonetheless, the wall-paintings may point in the direction of

9. Lichtenberger and Raja forthcoming.

a certain degree of luxury at least in phase 3 of the Ayyubid/Mamluk house in trench D (cf. field report in this volume). The slightly earlier period, the Abbasid period, is attested through the very small amounts of material also found scattered across the trenches on the hill either in the top soil or in disturbed and mixed fill layers.

The imports in the Northwest Quarter include Hellenistic Black Glazed pottery, Roman and Byzantine red slipped wares and a few other finds such as coins and glass but it would certainly be desirable to conduct more in depth research on the later imports – direct and indirect imports - through shapes applied in the workshops of Jarash.

### **The Use of the Northwest Quarter**

The oldest human activity found on the hill was reported in 2012 by a Neolithic flint tool. Flint is not uncommon in the area and the nearby site of Tall Abu Sultan is a locality rich in flint tools. The oldest ceramic evidence from the Northwest Quarter hitherto attested are a few fragments of Bronze Age Pottery, Hellenistic glass and Hellenistic pottery fragments (mainly in trench H, Hellenistic glass was located in trenches H and E) suggesting that some activity took place on top of the hill during the earlier periods. Finds from the following early Roman period are represented by a few coins and Eastern Sigillata A pottery primarily found on the northern and southern slopes of the hill. Especially on the northern slope of the hill Late Roman pottery has been attested and other find groups like glass and coins also yield evidence from the late Roman and early Byzantine periods such as ARS and common wares in the Northwest Quarter. Large amounts of Byzantine and Umayyad pottery from the area does, as in most parts of the city, attest to a flourishing local production during these periods. The later Islamic periods are now attested in the Northwest Quarter but remain scarce until the construction of the Ayyubid/Mamluk hamlet on top of the hill.

### **Ceramic Wares**

The characteristics of the different ware groups described in the previous report (Grey, Reddish/Red Brown, HMGPW and Jarash Bowl wares) will not be repeated but has been continued in the categories of this year. In 2013 it was possible to describe three new ware types which were found in the Northwest Quarter and further tentatively relate these to the Roman, Byzantine and Islamic periods. The places of production of these new wares are still unknown and will need further analyses to decide upon.

The 2009 revised edition of the Munsell Soil-Color Charts has been used for all colour readings during the 2013 campaign.

#### *Painted Buff Ware*

The Painted Buff Ware has only been found in a few examples, but is rather distinct (cat. no. 70). The ware has only been found in unstratified evidences and the dating of it relates to the shape of the vessels, the decoration and the comparison with stratified material from other excavations – primarily Pella and Bet She'an. The ware has a buff/light brown colour; it is rather finely levigated with a smooth surface, some small air pockets, few red-brown and black particles and a few lime eruptions on the exterior. It is hard fired, wheel made and brakes in clean sharp brakes. The ext. surface is: approximately 7.5YR 7/4 and the core varies between 5YR 6/6-6/8. The core is sometimes unevenly fired making the inner part of the core darker thus creating a sandwich core.

Comparable material from Bet She'an is dated to the Mamluk period, whereas the Pella material is tentatively placed in the Abbasid period or Fatimid-Mamluk period (cf. cat no. 70 for references). The ware thus corresponds to "Thin, decorated ware" and Group B in Pella. In the tables presented above the Buff Ware is counted within the Abbasid/Ayyubid column. The ware is rather rare in the excavation so far and is primarily found on top of the hill.



### *Green Ware*

The Green ware pottery has a rather rough undecorated surface with a green hue throughout. Iron may have produced the green colour. The ware is wheel made and fired crisp. It is medium levigated containing quartz and reddish-brown inclusions. The core of the ware varies between 5Y 6/6 – 6/4 and 2.5Y 6/6. The surface of the ware is approximately 5Y 6/4. The shapes of the ware are primarily long necked jugs, jars and a few tile fragments. The ware is found primarily on the northern slope of the hill and is regarded as an Islamic ware possibly of the Abbasid period (cat. nos. 77-78).

### *Orange Ware*

The Orange ware pottery has mainly been located within the Late Roman/Byzantine material of trench G but also in trenches H and A from the 2012 campaign. It is not found in any significant amount. It is characterised especially by the strong orange hue on the surfaces of the vessels. The surface is furthermore mottled and the surface colours thus range between 2.5 YR 6/8 and 5/8 and into a more yellowish hue 7.5 YR 7/6. The mottling can be around 2.5 YR 5/8 and sometimes less visible. The ware is medium levigated with a large amount of lime, some quarts in small pebble and as very fine glittering spots, a few black, a few reddish brown, and air pockets occur occasionally – indicating that the clay was not always well settled. Characteristic is the medium to large amounts of white inclusions which are visible on the surface. The core of the ware is sometimes sandwich layered the outer layers being app. 2.5YR 5/8 the inner reduced and thus yellowish brown. The clay

is hard fired and wheel made and the shapes are open vessels like larger bowls, basins and cooking pots. The shapes are mainly placed within the late Roman and early Byzantine material (cat. nos. 63, 85, 107).

The ware is most probably a plain ware and thus a slightly coarser version of the Jarash Bowl ware described in the report of the 2012 season.

### **The Coins** (Stefan Riedel)

In the first two excavation campaigns in the Northwest Quarter of Jerash a total of 199 coins were found. 64 stem from the 2012 campaign and 135 from the 2013 campaign. All coins are copper alloys and their weight ranges from less than 0,5 g to more than 20 g. The excavated coins are not surprisingly heavily corroded and incrustated and most of them show traces of use, which makes it almost impossible to make precise observations without previous professional cleaning. Some coins which seemed to be from promising contexts or in their own rights worth to have a closer look at were cleaned and conserved during the 2012 and 2013 campaigns<sup>10</sup>.

Generally, it must be mentioned that in no case the studied coins are of value concerning the dating of the contexts they were found in. This holds especially true for undisturbed contexts such as collapses. The coins were all older than most of the other finds from the same contexts and often coins of different dates were found in the same contexts. The contexts in question date to the Byzantine period and mainly to the Islamic period. This circumstance indicates that the coins in Jarash circulated for quite a long time and were not directly replaced by new emissions<sup>11</sup> but probably used according to

10. I am very grateful to Helle Strehle for carrying out the cleaning and conservation work of these coins enabling the studies presented here.

11. Especially Byzantine coins were still used in the region at least until the reform of Abd al-Ma'lik around the end of the 7th century (cf. Heidemann 1998, p. 95–99; Bellinger 1938, p. 20). This basically concerns the influx of Byzantine copper

coins but it might also be assumed that older coins were still in use without countermarking or overstriking them. The example of an overstruck Diocletian coin about 400 years later (Heidemann 1998, p. 98) at least proves that older coins were still circulating. The long circulation of Byzantine coins within the Byzantine Empire itself is also witnessed in hoard finds (cf. Gândilă 2009, p. 162).

their metal's value. The presence of Roman and Byzantine coins in later period contexts (e.g. in the North-room of trench D, ev. 17, 18 and 19 – of late Byzantine to early Umayyad date) also contributes to this suggestion. Furthermore, it is remarkable that almost no coins from the Islamic period were recovered.<sup>12</sup> Most of the coins are of light weight and diameter (less than 1g and around 1cm in diameter or less) which indicates that they are Byzantine nummi although they are often too badly preserved to test this hypothesis. Generally, the coins found and studied range in date from the early Roman to the early Islamic period with a peak in Byzantine times.

The following catalogue gives an overview of some of the better preserved and cleaned coins which nevertheless represent the spectrum of the numismatic material from the Northwest Quarter recovered up to now.

#### **Glass Finds** (Holger Schwarzer)

During the campaign in 2013 almost 300 glass items, generally quite fragmented, came to light in trenches D–H in the Northwest Quarter of Jerash. Most of them stem from the middle/late Roman and early Byzantine/early Umayyad periods.<sup>13</sup> The vessels were predominantly free-blown and are likely to have had a local origin. All Hellenistic, Roman and Byzantine pieces were found in later strata of Islamic date and their original contexts are lost.

Early period material is rarely encountered among the glass finds. Only a few sherds can be assigned to the Hellenistic period. They belong to cast grooved bowls showing a conical or hemispherical shape (cat. nos. 153-154). The early Roman imperial period does not seem to be

represented. Typical leading forms of the 1st and early 2nd centuries AD are completely missing. The majority of the Roman glass vessels – as far as determinable – can be dated to after the middle of the 2nd until the late 4th centuries AD. They are mostly characterized by a dark weathering. Some types of bowls representing common dishes should be mentioned, such as examples with a crimped strip-handle (cat. no. 155), examples with a high folded base-ring (cat. no. 156), examples with a horizontal double fold in the glass wall (cat. no. 159) and examples with a broad out-folded rim (cat. no. 160). Several other forms and types were also attested and await the final publication. The fine tableware occurs only in one small fragment of a cut-decorated bowl, which is certainly an import (cat. no. 157).

The production of some vessel types ranged from the mid-/late Roman period into the early Byzantine period. This applies for instance to bottles and jugs with a thick trail below the rim (cat. no. 158) or a spiral trail around the neck (cat. no. 161). It is the same with conical goblets (cat. no. 163), double kohl tubes (cat. no. 164), cups decorated with a blue spiral trail (cat. no. 165), and mould-blown flasks or jugs with vertical ribs (cat. no. 162). Glass certainly of the early Byzantine period include polycandelon lamps with a stemmed hollow foot (cat. no. 167) and different goblet types like those with a hollow stem and a foot with tubular edge (cat. no. 168). White weathering is characteristic for the glass from this period.

Sometimes one cannot decide whether an object has its origin in an early Byzantine or in an early Umayyad glass factory because no

12. So far, only two coins might belong to the Islamic period. One found 2012 beneath a collapse within trench C (cf. report on the 2012 campaign), which probably dates to the time after the coinage reform carried out by Abd al-Malik and another one from the 2013 campaign (from a mixed layer in the large cistern, i.e. trench F), which has not been cleaned but seems to bear three lines of Arabic letters on its reverse.

13. «Early Byzantine» means here – in contrast to the usual

definition in the archaeological research of the Near East – the whole period from the division of the Roman empire in 395 AD and the Sassanian (614 AD)/Islamic (635 AD) conquest of Gerasa. In my opinion this allows a less problematic comparison with other areas of the Byzantine empire, where the internal chronology (early, mid and late Byzantine) has a different framework.

differences in material and shape are visible.<sup>14</sup> Such difficulties relate to goblets such as those with a solid stem and a solid foot (cat. no. 169) and those with a solid foot and a solid stem with one knob (cat. no. 170) as well as to polycandelon lamps with solid knobbed stems (cat. no. 171). They suggest a continuous production of local Byzantine glassmakers under the new Islamic rulers.

Without a significant context it is impossible to verify the date of two monochrome beads (cat. no. 172) – the only glass jewellery that was found – as well as of three single glass tesserae (cat. no. 173) whose associated mosaics are lost. Cast window panes, also represented in the finds from the Northwest Quarter (cat. no. 174), were used in Jarash throughout the period from the mid-Roman times to the early Islamic period.

### **Chronology**

Hellenistic: 332 BC – 63 BC

Roman: 63 BC – early 4<sup>th</sup> century AD

Byzantine: early 4<sup>th</sup> century AD – late 5<sup>th</sup> century AD

Late Byzantine: late 5<sup>th</sup> century AD – mid-7<sup>th</sup> century AD

Umayyad: 7<sup>th</sup> century AD – end of 8<sup>th</sup> century AD

Abbasid: 9<sup>th</sup> century AD – 10<sup>th</sup> century AD

Fatimid: 11<sup>th</sup> century AD – 12<sup>th</sup> century AD

Ayyubid: 12<sup>th</sup> century AD – mid-13<sup>th</sup> century AD

Mamluk: mid-13<sup>th</sup> century AD – 15<sup>th</sup> century AD

### **Catalogue**

The drawings of the catalogued objects were produced by architect Jens Christian Pinborg, archaeology students Dorothea Csitneki, Eicke Grasner, Signe Krag, Signe Bruun Kristensen and Nadia Schmidt-Larsen. They were prepared for publication by Signe Bruun Kristensen. Photos

were taken by photographer Michael Benecke and archaeology student Philip Ebeling.

### **Arrangement of Catalogue:**

Inventory number

Title

Figure/Illustration

Measurements (in cm)

Munsell (when not described in the described ware groups)

Description (incl. material)

References

Date

### **Arrangement of the Coin Catalogue:**

Inventory number

Figure/-s

Material, denomination

Weight (in g), diameter (in cm), die position

Mint, minting authority

Description

References

Date

### **Catalogue Abbreviations:**

AE: Copper-alloy ('bronze')

D: Depth

diam.: diameter (in cm)

ext: exterior

h: die position ('hour' – clockwise)

H: Height

int: interior

L: Length

Obv.: obverse

Rev.: reverse

### **Fine Ware**

#### **Hellenistic (PE)**

1.

J13-Ha/a1-13-14

Base, fragmented.

Fig. 1.

Munsell: core1: Black/Grey spots in the brown core, 10YR 7/2; core2: GLEY1 4/N; int.: 10YR

---

14. For discussion of that problem see Meyer (1989).

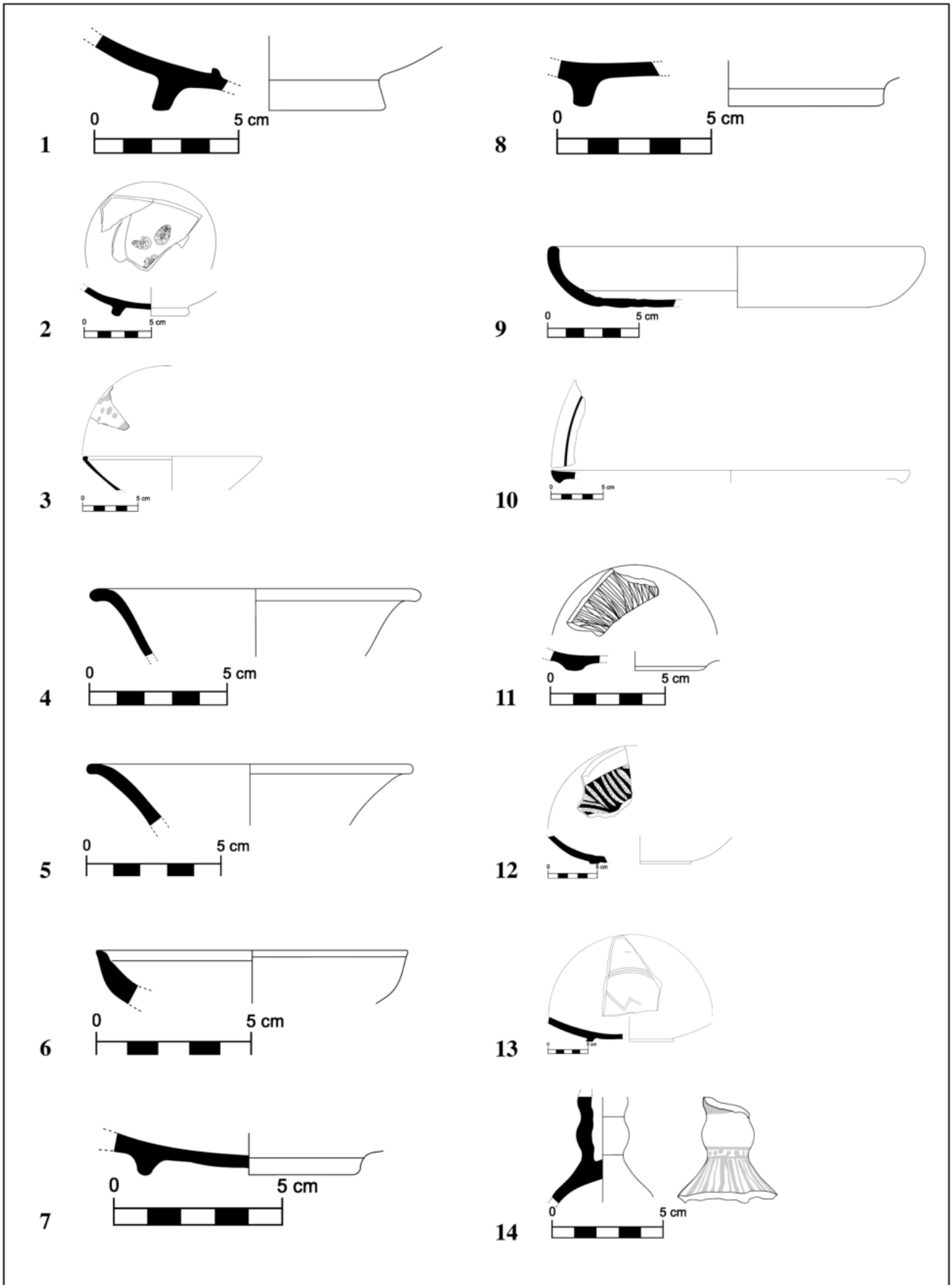

14/1; ext.: 10YR 14/1.

Diam. (base): 8, (rim): 2; H.: 2.5; L.: 6.3; T. (max.): 0.8, (min.) 0.4.

Fish plate; medium fired and finely levigated and well settled clay.

*References:* Metzger (1969), 47-48, 23; pl. 12, 23; Kenkel (2012), taf. 15, Sa2.8, 2<sup>nd</sup> – 1<sup>st</sup> century BC.

2.

J13-Ha/a1-13-31

Base, fragmented.

Fig. 2.

Munsell: core: 5YR 4/4; slip: 10YR 2/1 + GLEY 1 2,5/N.

Diam. 5.8; H.: 2, 15; L.: 7.5; T.: 0.4.

Black Glazed bowl or plate; hard-fired and finely levigated clay; deco.: three oval shaped stamps with floral motifs. Irregularly set.

*References:* Rotroff (1997), Form: 843, fig. 57.

Late 2<sup>nd</sup> – 1<sup>st</sup> century BC.

### **Nabataean (PE)**

3.

J13-Ha/a1-13-55

Rim, fragmented.

Fig. 3.

Munsell: core: 2.5YR 6/6; int.: 5/6 7.5YR; ext.: 2.5YR 6/6; slip: 2.5YR 7/2.

Diam.: 16; H.: 2; L.: 3.1; T.: 0.1.

Plate or open bowl, hard-fired and finely levigated; painted deco.: dark-brownish spots.

*References:* Hammond (1965), Bowl no. 15, pl. LIX; Zayadine, (1974), no. 21; pl. LXII, 21, pl. LXIV, 3; Schmid (1993), fig. 111, 113.

1<sup>st</sup> century AD.

### **Eastern Sigillata A (ESA) / (Çandarlı ware) (PE)**

#### *Rims*

4.

J13-Fa-17-16

Rim, fragmented.

Fig. 4.

Munsell: core: 10YR 7/4; slipped int. and ext.: 10R 4/6.

Diam. (rim): 12; H.: 2.4; L.: 6.5; T. (max.): 0.45;

(min.): 0.3.

Bowl. The rim is rounded and folded outwards. Hard fired, rather finely and well-settled clay.

*References:* Kenkel (2012), taf. 10, ETS10.3.

Early Roman (1<sup>st</sup> century BC – mid 1<sup>st</sup> century AD).

5.

J13-Ha/a1-14-4

Rim, fragmented.

Fig. 5.

Munsell: core: 7.5YR 8/3; slipped int. and ext.: 10R 4/6.

Diam. (rim): 12; H.: 2.2; L.: 6.6; T. (max.): 0.5; (min.): 0.3.

Rim of an open vessel. The rim is round to square; hard fired, finely levigated and well-settled clay. Wheel marks visible below slip.

*References:* Kenkel (2012), taf. 10, ETS10.3.

Early Roman (1<sup>st</sup> century BC – mid 1<sup>st</sup> century AD).

6.

J13-Ha-13-13A

Rim, fragmented.

Fig. 6.

Munsell: core: 7.5YR 8/3; slipped int. and ext.: 2.5YR 4/6.

Diam. (rim): 10; H.: 1.7; L.: 3,1; W. (rim): 0.3; T. (max): 0.7; (min.): 0.4.

Bowl. Hard-fired and very finely levigated clay.

*References:* Hayes (1972), ESA Form 3, 321; fig. 64 Form 3.

Roman (Late 2<sup>nd</sup> – early 3<sup>rd</sup> century AD).

#### *Bases*

7.

J13-Ha/a1-13-26

Fig. 7.

Base, fragmented.

Munsell: core: 2.5Y 4/8, slip: 10R 4/8.

Diam.: 6.6; H.: 1.2; L.: 6.2; T. (max.): 0.5, (min.): 0.3.

Bowl/plate, Hard fired and finely levigated with some air pockets.

*References:* Hayes (1992), fig. 71, 11; Hayes

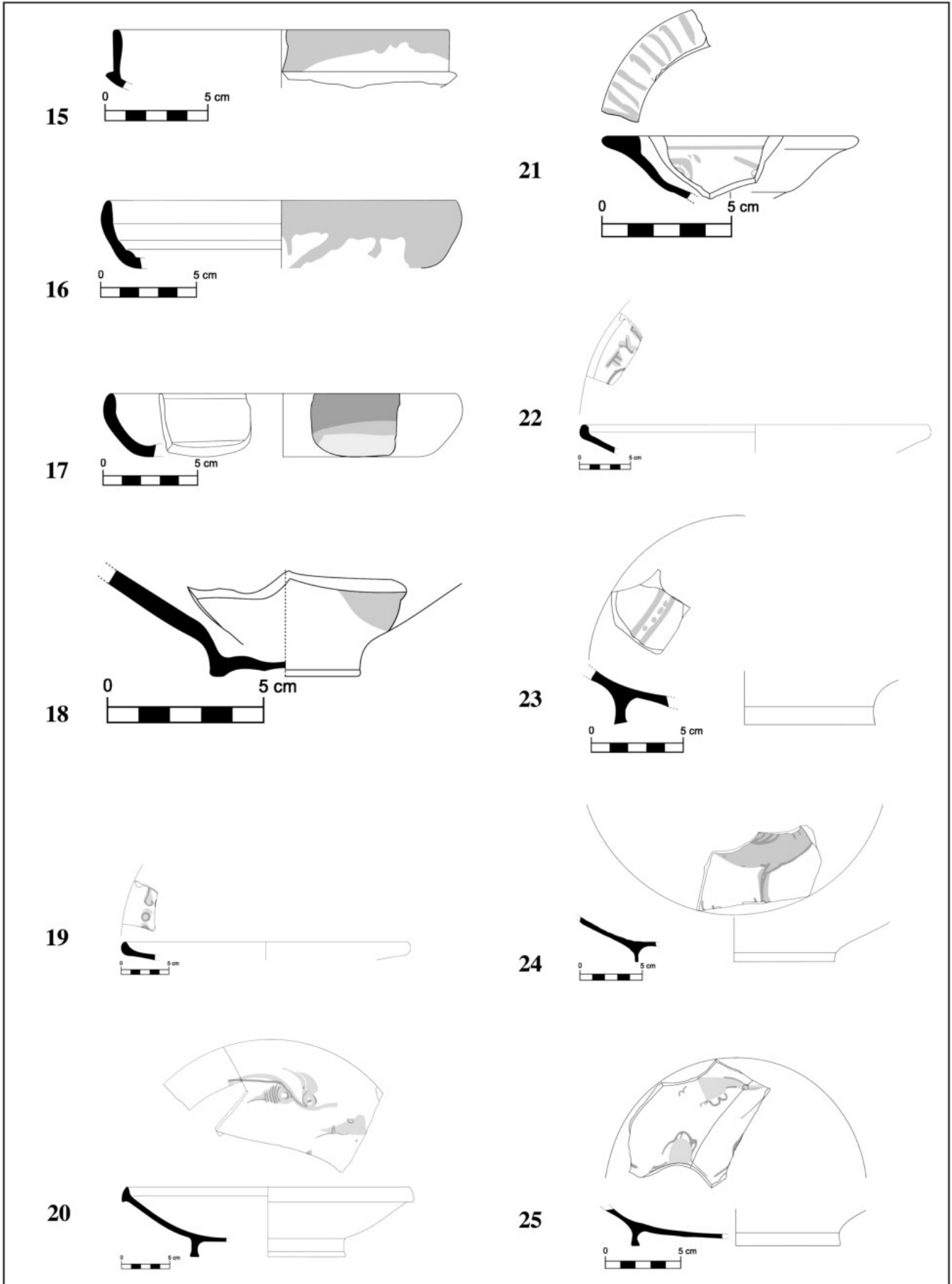

(1997), fig. 20, 7; 19, 2.

Early Roman (1<sup>st</sup> century AD).

8.

J13-Fc-15-23

Base, fragmented.

Fig. 8.

Munsell: core: 2.5YR 7/6; slipped int. and ext.: 7.5YR 5/8.

Diam. base: 10; H.: 1.5; L.: 5; W.: 0.8; T.: 0.5.

Bowl, hard fired and rather finely levigated clay.

*References:* Kenkel (2012), taf. 11, ETS10.6.

Early Roman (Late 1<sup>st</sup> century BC – mid 1<sup>st</sup> century AD).

### **African Red Slip (ARS) (PE)**

*Rims*

9.

J13-Ec-27-52 and 53.

Fig. 9.

Rim and base, fragmented.

Munsell: core: 2.5YR 6/2; int.: 2.5YR 6/8; ext.: 2.5YR 6/8.

Diam. base: 16; rim: 20.5; H.: 2.2; L.: 15.7; T. (max.): 0.5; (min.): 0.3.

Bowl, hard-fired and rather coarse clay.

*References:* Hayes (1972), ARS Form 181; Rason (1986), fig. 17, 2.

Roman (Late 2<sup>nd</sup> – 4<sup>th</sup> century AD).

10.

J13-Gf-30-34

Rim, fragmented.

Fig. 10.

Munsell: core, int. and ext.: 10R 5/8.

Diam. (rim): 34, H.: 1.2; L.: 8.5; W. (rim): 1.1; T.: 0.6.

Open shaped vessel. Rim is decorated with an incised line, following the wheel marks. Hard fired and finely levigated clay with some air pockets; deco.: incised line circulating rim at int.

*References:* Hayes (1972), ARS Form 67, fig. 19, no. 28.

Byzantine (1<sup>st</sup> half of 5<sup>th</sup> century AD).

*Bases*

11.

J13-Ec-13-36

Fig. 11.

Base, fragmented.

Munsell: core, int., ext. and slip: 2.5YR 6/6.

Diam.: 6, H.: 0.4; L.: 4,0; W.: 0.8, T. (max.): 0.4; (min.): 0.3.

Bowl or plate, hard-fired and finely levigated clay with some air pockets; deco.: thin, impressed lines, radiating from the centre towards the rim.

*References:* Hayes (1972), ARS Form 91.

Byzantine (2<sup>nd</sup> half of the 5<sup>th</sup> century AD).

12.

J13-Gf-33-8

Base, fragmented.

Fig. 12.

Munsell: core, int. and ext.: 10R 5/8

Diam. (base): 10; H.: 2.8; L.: 8.0; W.: 0.4; T. (max.): 0.8; (min.): 0.6.

Plate or bowl, hard-fired and finely levigated clay; deco: on the int. face impressed lines, feather-rouletting.

*References:* Hayes (1972), ARS Form 91 B.

Byzantine (450-530 AD).

### **Late Roman C (LRC) (PE)**

13.

J13-F-0-3

Base, fragmented.

Fig. 13.

Munsell: core, int., ext. and slip: 10R 5/8.

Diam. base: 11; H.: 3.1; L.: 9.7; T. (max.): 1.1 (rim); (min.): 0.95.

Hard fired, medium levigated and well-settled clay. Incised deco. int.: three parallel, horizontal grooves running along the body. Two parallel lines in a zig-zag-pattern in the centre.

*References:* Form: Hayes (1972) LRC 3, no. 19. Late Byzantine (6<sup>th</sup> century AD).

### **White Painted Fine Ware**

14.

J13-Fa-10-11-2

Stem, fragmented.

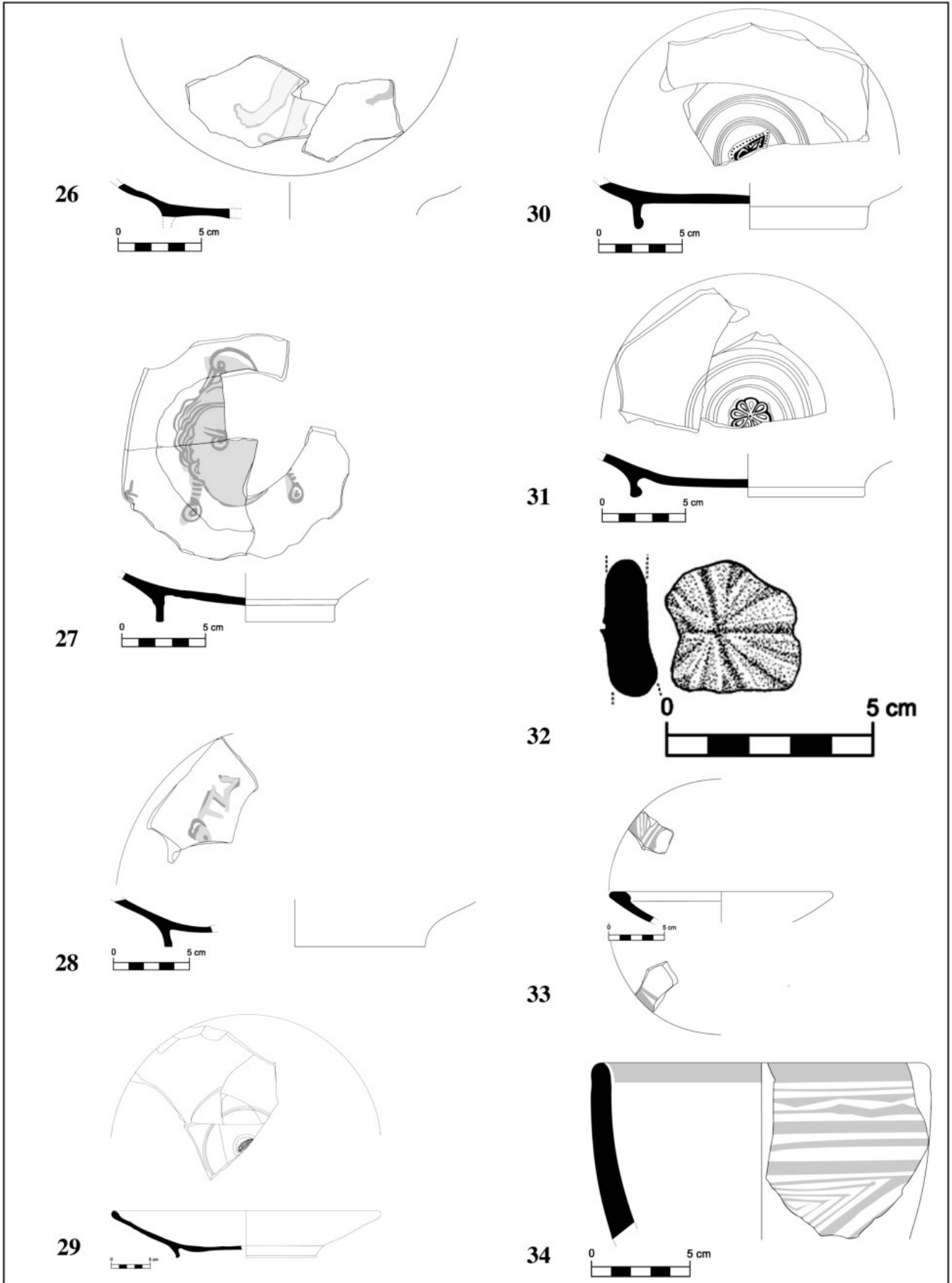



Fig. 14.

H.: 4.7.

Munsell: core: 2.5YR 5/8; int.: 2.5YR 5/8; paint: 2.5YR 3/4 and 10R 8/1.

Presumably a closed shape; small lime inclusions, hard fired; deco: treated with a white paint and red painted vertical lines ending at two horizontal lines with dots in between.

*References:* Uscatescu (1996), p. 311, fig. 41 no. 65.

Byzantine.

### Local Fine Wares (PE)

#### Rims

15.

J13-Gf-33-10

Rim, fragmented.

Fig. 15.

Munsell: core1: 2.5YR 6/6; int.: 10R 4/8; ext.: 2.5YR 6/6; 10R 4/8.

Diam. (rim): 16; H.: 2.8; L.: 9.1; W. (rim): 0.5; T. (max.): 0.5; (min.): 0.4.

Local fine ware bowl, hard-fired and fine levigated clay, remains of paint on int. and ext. surface.

*References:* Braemer (1986), Fig. 8; Lapp (1961), p. 180, E. Qumrân II; Kenkel (2012), Taf. 11, ETS13.2; Uscatescu (1996), p. 253, no. 316, fig. 67, 316.

Early Roman (2<sup>nd</sup> half of 1<sup>st</sup> century AD).

16.

J13-Gb-12-73-74-75

Rim, fragmented.

Fig. 16.

Munsell: core1: 10YR 4/1; core2: 2.5YR 6/6; int.: 10YR 8/4 – 2.5YR 6/6; ext.: 7.5YR 8/4; slip: 5YR 4/4; wash: GLEY2 4/10B; ext. painting: 5YR 6/4 – 2.5YR 5/8.

Diam. (rim): 18; H.: 3.5; L.: 15.6; W. (rim): 0.6; T. (max.): 0.7; (min.): 0.6.

Deep bowl, hard-fired and rather finely levigated clay. Very worn slip ext.

*References:* Rasson (1986), fig. 17, 2; Hayes (1972), ARS Form 181, Kraeling (1938), p. 558, fig. 36, no. 1.

Roman (2<sup>nd</sup> half of 2<sup>nd</sup> century – 1<sup>st</sup> half of 3<sup>rd</sup> century AD).

17.

J13-Gb-12-71

Rim with small part of base, fragmented.

Fig. 17.

Munsell: core: 2.5YR 6/6; int.: 2.5YR 3/3; ext.: 2.5YR 3/4 – 5YR 2.5II – 10YR 7/4.

Diam. (rim): 18; H.: 3.3; L.: 4.7; W. (rim): 0.6; T. (max.) 0.6; (min.): 0.5.

Bowl, hard-fired and medium levigated clay with air pockets. Slipped int. and partly ext. with a dark brown slip.

*References:* Rasson (1986), Fig. 17, 2; Hayes (1972), ARS Form 181.

Roman (2<sup>nd</sup> half of 2<sup>nd</sup> century – 1<sup>st</sup> half of 3<sup>rd</sup> century AD).

#### Base

18.

J13-Gf-33-9

Base, fragmented.

Fig. 18.

Munsell: core1: 2.5YR 6/6; int.: 10R 4/8, ext.: 2.5YR 6/6; slipped int.: 10R 4/8; paint ext.: 10R 4/8.

Diam. (base): 4.8; H.: 3.3; L.: 8.6; W. (base): 0.5; T. (max.): 0.6; (min.) 0.5.

Open shape, hard fired and medium levigated. Traces of paint or slip on the ext.

Not datable

### Jarash Bowls<sup>15</sup> (NSL)

#### Painted decoration

#### Rims

T: Thickness

W: Width

Wt: weight

All measurements are given in cm.

15. Munsell not indicated but follow the pattern of colours

described in 2012 catalogue.

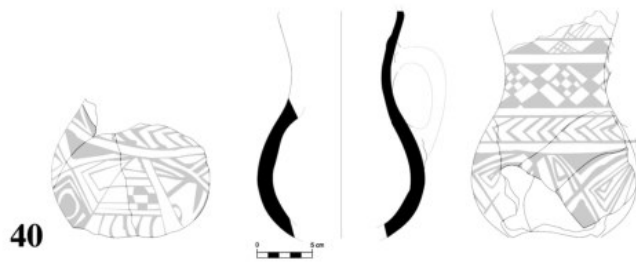
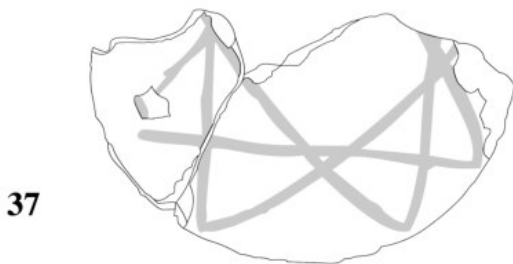
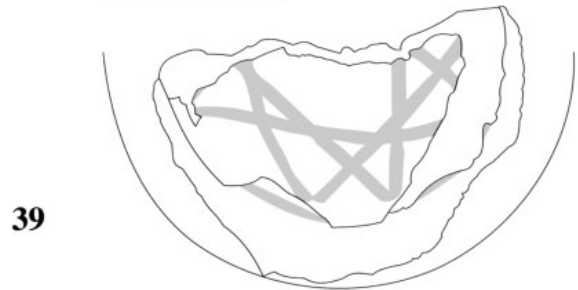
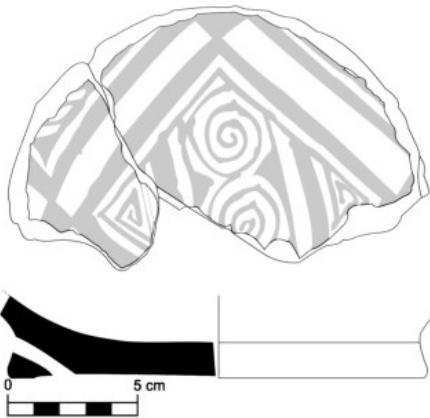
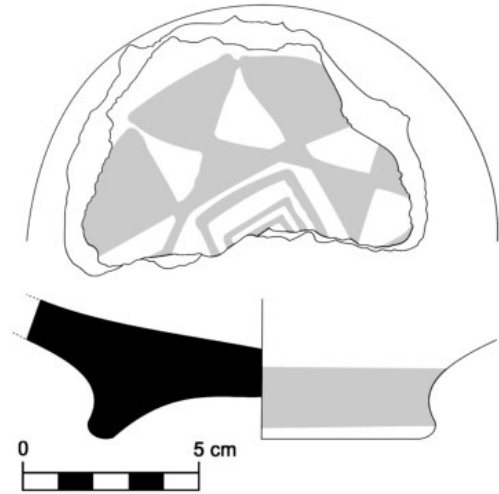
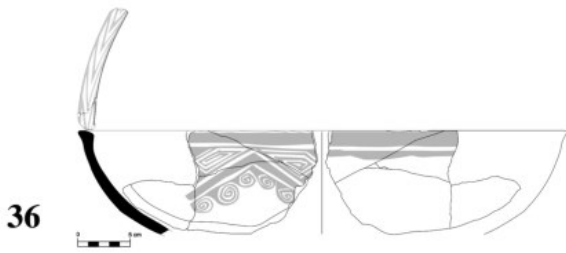
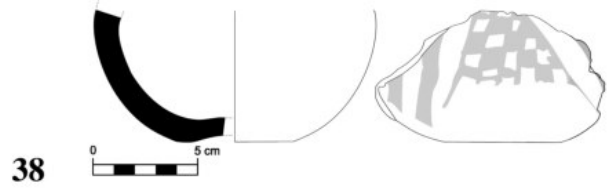
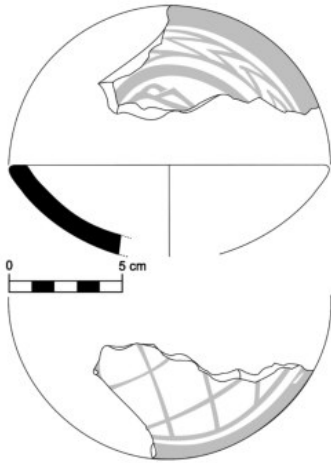

**Catalogue Authors:**

AHS – Annette Højen Sørensen  
AL – Achim Lichtenberger  
AMB – Anders Meander Bjerregaard  
AR – Anne Riedel  
HS – Holger Schwarzer

NSL – Nadia Schmidt-Larsen  
PE – Philip Ebeling  
RR – Rubina Raja  
SBr – Signe Bruun Kristensen  
SKr – Signe Krag  
SR – Stefan Riedel

## Catalogue

### Danish-German Jarash Northwest Quarter Project 2013

19.

J13-Fc-40-84

Rim, fragmented.

Fig. 19.

Diam.: 28; H.: 2.5.

Outwards-flattened rim; deco.: reddish paint with white filling, floral?

*References:* rim shape: Watson (1989), p. 225, fig. 1.6a; deco.: Uscatescu (1996), p. 324, fig. 59 no. 195.

Byzantine – Umayyad (6<sup>th</sup> – 7<sup>th</sup> century AD).

20.

J13-Ed-19-12

Rim and base, fragmented.

Fig. 20.

Diam.: 16; H.: 7.2.

Rim and raised ring base, half of the bowl is preserved, two joining fragments; deco.: white reddish painted decoration, stylized grapes.

*References:* rim shape: Watson (1989), p. 225, fig. 1.5f; deco.: Uscatescu (1996), p. 317, fig. 47 no. 149; deco.: Uscatescu (1996), p. 321, fig. 174.

Byzantine – Umayyad (6<sup>th</sup> – 7<sup>th</sup> century AD).

21.

J13-Fb-40-125

Rim, fragmented.

Fig. 21.

Diam.: 10; H.: 2.4.

Deco: white slip and painted pattern on the interior surface and painted red lines around the rim.

*References:* rim shape: Watson (1989), p. 225, fig. 1d; deco.: Uscatescu (1996), p. 325, fig. 55 no. 206.

Byzantine – Umayyad (6<sup>th</sup> – 7<sup>th</sup> century AD).

22.

J13-Fc-52-12

Rim, fragmented.

Fig. 22.

Diam.: 34; H.: 2.7.

Flattened rim; deco.: painted Greek letters ('ΠΥ') int. below rim, reddish paint with white filling.

*References:* rim shape: Watson (1989), p. 225, fig. 1.2a; deco.: Uscatescu (1996), p. 336, fig. 66 no. 306.

Byzantine – Umayyad (6<sup>th</sup> – 7<sup>th</sup> century AD).

*Bases*

23.

J13-Dab-17-18

Base, fragmented.

Fig. 23.

Diam.: 14; H.: 3.1.

Raised ring base, fragmented body; deco.: two red painted lines running horizontally on the lower part of the body, white filling.

*References:* base shape: Uscatescu (1996), p. 314, fig. 44 no. 108; deco.: Watson (1989), p. 240, fig. 1.

Byzantine – Umayyad (6<sup>th</sup> – 7<sup>th</sup> century AD).

24.

J13-Eab-7-5

Base, fragmented.

Fig. 24.

Diam.: 16; H.: 3.6.

Raised ring base and fragmented body; deco.: painted figure (animal/bird) with white filling on the int. surface.

*References:* deco.: Uscatescu (1996), p. 332, fig. 62 no. 261; Watson (1989), p. 247, fig. 3.

Byzantine – Umayyad (6<sup>th</sup> – 7<sup>th</sup> century AD).

25.

J13-Ebd-14-30

Base, fragmented.

Fig. 25.

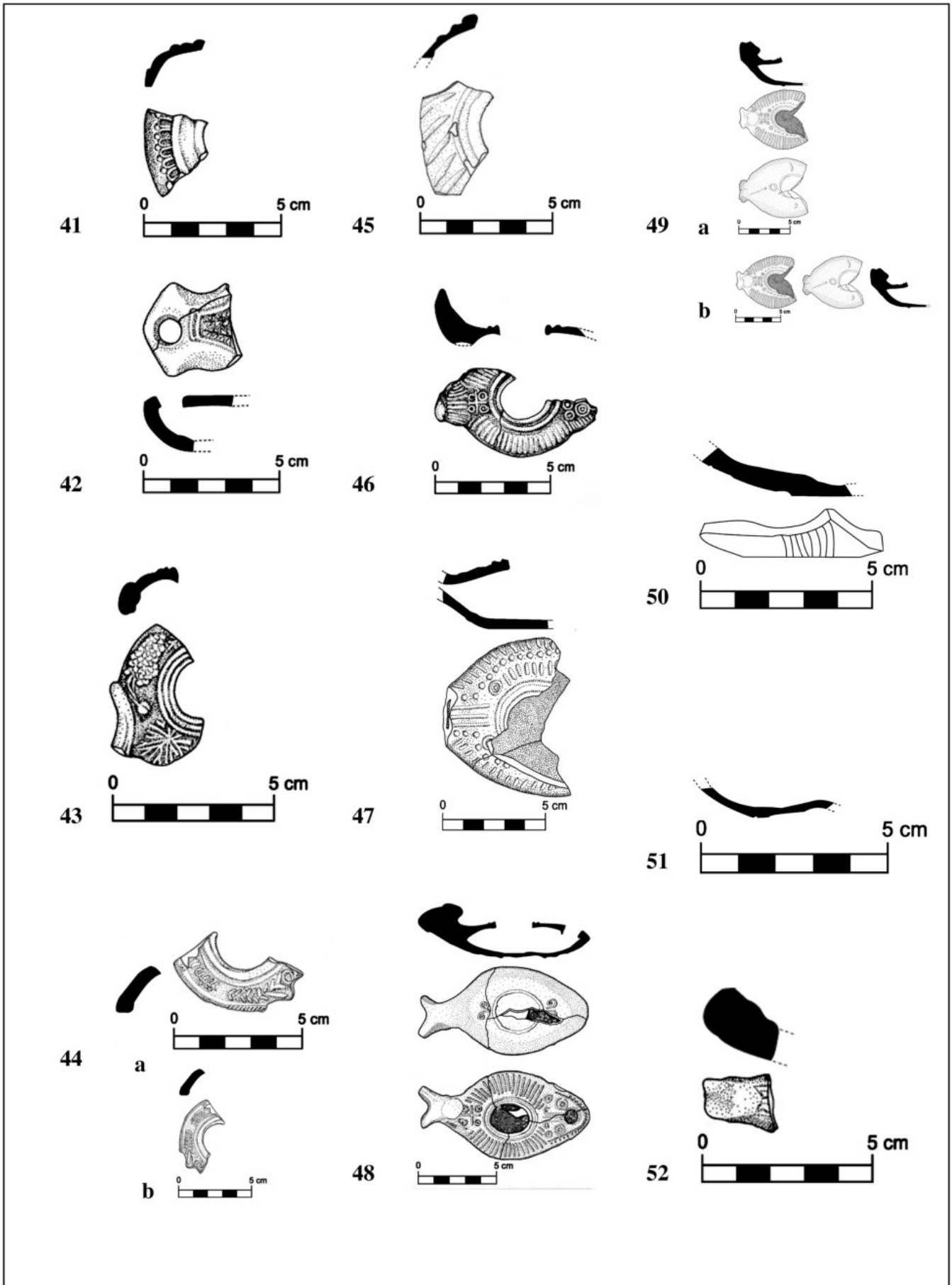

Diam.: 14; H.: 2.4.

Raised ring base, fragmented body, two joining pieces; deco.: painted on inside surface.

*References:* Uscatescu (1996) p. 334 fig. 64 no. 286; Watson (1989) p. 251, fig. 14.4.

Byzantine – Umayyad (6<sup>th</sup> – 7<sup>th</sup> century AD).

26.

J13-Ed-18-99 and 101

Base, fragmented.

Fig. 26.

Diam.: 15; H.: 2.

Ring base broken off; deco.: two front feet/paws (person/animal), drawn with reddish paint and white filling.

*References:* deco.: Uscatescu (1996), p. 322, fig. 52 no. 179.

Byzantine – Umayyad (6<sup>th</sup> – 7<sup>th</sup> century AD).

27.

J13-Fb-40-126

Jerash bowl base, well preserved.

Fig. 27.

Diam.: 10.6; H.: 2.9.

Raised base; deco.: painted face of human head wearing a Phrygian cap on int. surface with reddish paint and white filling.

*References:* base shape: Uscatescu (1996), p. 325, fig. 55 no. 203; deco.: Watson (1989), p. 248, fig. 12.6.

Byzantine – Umayyad (6<sup>th</sup> – 7<sup>th</sup> century AD).

28.

J13-Gf-30-6

Base, fragmented.

Fig. 28.

Diam.: 17; H.: 3.1.

Raised ring base; deco.: reddish painted Greek letters ('ΤΩ') with white filling.

*References:* base shape: Uscatescu (1996), p. 325, fig. 55 no. 203; deco.: Uscatescu (1996), p. 336, fig. 66 nos. 306 and 308.

Byzantine – Umayyad (6<sup>th</sup> – 7<sup>th</sup> century AD).

### **Stamped decoration**

#### *Rim*

29.

J13-Fh-29-17

Rim and base, fragmented.

Fig. 29.

Diam.: 18; H.: 6.1

Intact profile of five joining pieces; deco.: stamped leaf ornament at centre and concentric incised lines encircling the stamp.

*References:* shape: Uscatescu (1996), p. 316, fig. 46 no. 140; deco.: Uscatescu (1996), p. 329, fig. 59 no. 243.

Byzantine – Umayyad (6<sup>th</sup> – 7<sup>th</sup> century AD).

#### *Bases*

30.

J13-Ebd-14-31

Base, fragmented.

Fig. 30.

Diam.: 14; H.: 2.7.

Raised ring base, fragmented body, two joining pieces; deco.: stamped leaf ornament and concentric incised lines encircling the stamped decoration.

*References:* base shape: Uscatescu (1996), p. 319, fig. 49 no. 164; deco.: Uscatescu (1996) no. 244; Lichtenberger, Raja and Sørensen (forthcoming), no. 28.

Byzantine – Umayyad (6<sup>th</sup> – 7<sup>th</sup> century AD).

31.

J13-Gd-4-9 and Gd-7-12

Base, fragmented.

Fig. 31.

Diam.: 14; H.: 2.5.

Raised ring base consisting of two joining fragments; deco.: stamped floral ornament, and concentric incised lines encircling the stamped decoration.

*References:* base shape: Uscatescu (1996), p. 329, fig. 59 no. 241; deco.: Uscatescu (1996), p. 330, fig. 60 no. 247, Watson (1989), p. 228, fig. 2b.iv.

Byzantine – Umayyad (6<sup>th</sup> – 7<sup>th</sup> century AD).

### **Cut Ware / Kerbschnitt (AHS)**

32.

J13-Eb-17-5

Fig. 32.

Body, fragmented.

Munsell: core: 7.5R 4/1 and 5/6; int.: 7.5YR 6/3; ext.: 7.5YR 5/1.

H.: 3.2; L.: 2.8; T.: max: 0.88, min. 0.4.

Cut ware, small body fragment, reduced firing, deco.: Kerbschnitt

*References:* Example from Jerash – not identical deco. from Gawlikowski's 1982 excavation exhibited in Jerash Museum show case "Byzantine Age 324-630 A.D."; Gawlikowski (1996), p. 117; Stacey (2004), p. 93 fig. 5.6; Walmsley (1995), p. 668 "Ware 19", fig. 9.6-7; Avissar (2005), p. 49 fig. 2.10 no. 2.

Byzantine or Abbasid.

### **Handmade Geometric Painted Ware (HGPD) (SBr)**

#### *Rims*

33.

J13-Dab-7-8

Rim, fragmented.

Fig. 33.

Munsell: core: 2.5YR 6/6; int.: 10YR 8/2 and 7.5YR 3/1, ext.: 10YR 8/2 and 7.5YR 3/1.

Diam.: 20; H.: 2.7; L.: 3.9; T. min.: 0.7; max.: 0.8.

Bowl, convex sloping neck and body with flattened out

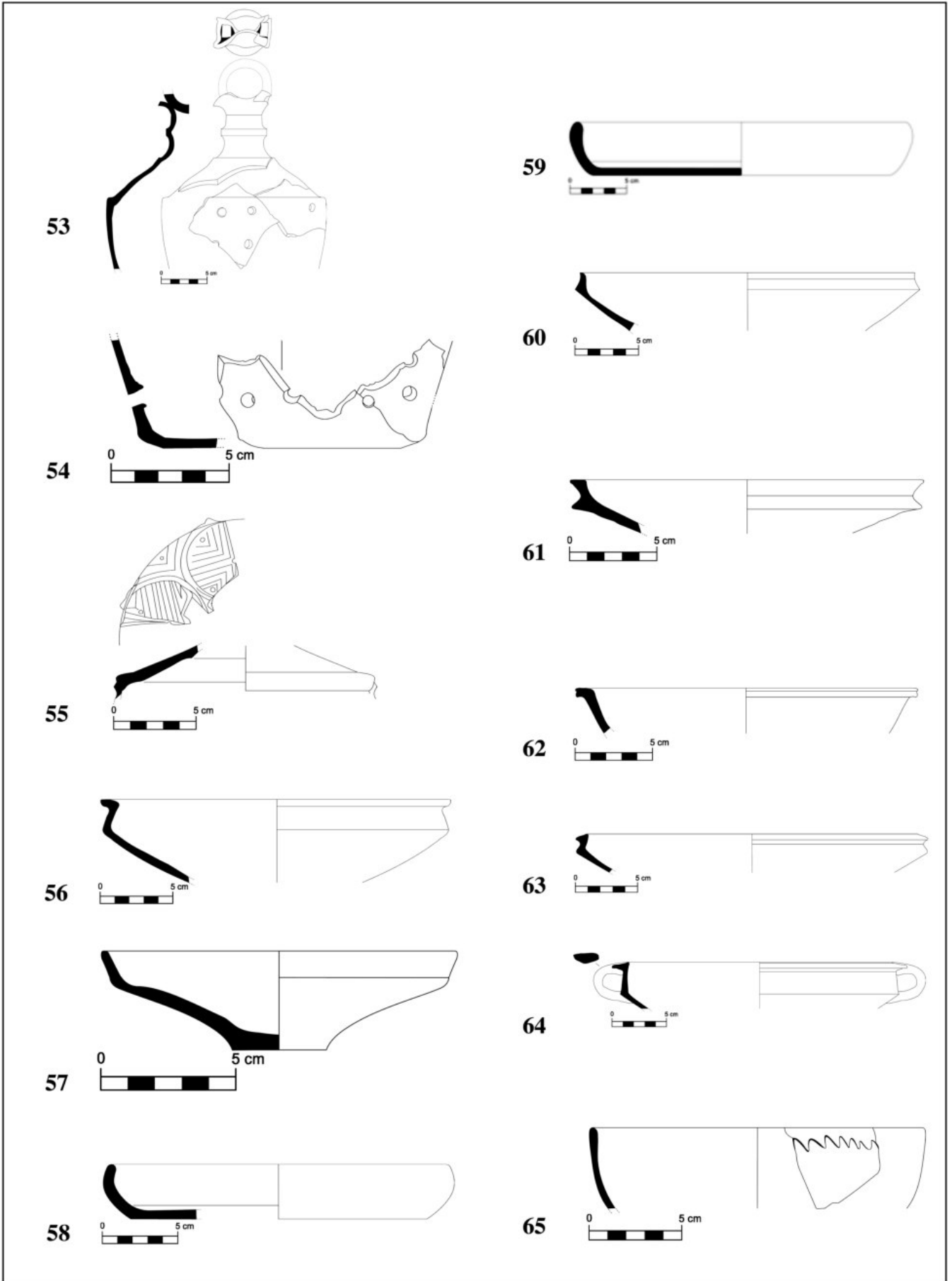

sloping rim. Ledge at int. circulating rim; deco. int.: two horizontal lines, straight and wavy; ext.: two horizontal lines, circulating rim; rim: two horizontal lines framing four sloping lines.

*References:* deco.: Franken (1975), p. 184, no.: 1; shape: Walker (2009), p. 101, no. 3, Franken (1975), p. 178, no.1, Franken (1975), p. 182, no.14; Lichtenberger, Raja and Sørensen (forthcoming), fig. 38.

Late Ayyubid – Mamluk (Late 12<sup>th</sup> – 14<sup>th</sup> century AD).

34.

J13-D-9-3

Rim, fragmented.

Fig. 34.

Munsell: core: 5YR 7/6; int.: 7.5YR 7/6, ext.: 2.5YR 3/3; slip: 10YR 8/3.

Diam.: 16; H.: 8.9; L.: 7.7; T. min.: 0.9; max.: 1.

Jug; slightly out sloping neck/body. Rounded, straightened rim, vague ledge under rim ext.; painted deco. int.: two horizontal lines, straight and wavy; deco. ext.: six horizontal lines, not linear circulating rim; triangular pattern on body/neck; rim: dark line covering rim.

*References:* deco.: Franken (1975), p. 184, fig. 10; shape: Franken (1975), p. 182, fig. 22; Thuesen (1988), p. 228, no. 10.

Late Ayyubid – Mamluk (Late 12<sup>th</sup> – 14<sup>th</sup> century AD).

35.

J13-D-9-4

Rim, fragmented.

Fig. 35.

Munsell: core: 10YR 8/3 and 7.5YR 7/6; int.: 10YR 7/2 and 2.5YR 3/3 ext.: 10YR 8/2 and 2.5YR 3/4.

Diam.: 14; H.: 4.2; L.: 9.5; T. min.: 0.6; max.: 0.8.

Bowl, convex sloping neck/body, flattened rim; deco. int.: pointed lines circulating body, framed by two horizontal lines. Broad horizontal line encircling a geometric pattern; deco. ext.: crosshatched lines at covering outer surface, broad line circulating rim. Rim: dark line covering rim.

*References:* deco.: Tholbecq (1997-1998), p. 164, fig. 16, Franken (1975), p. 184, no. 16; Franken (1975), p. 195, no. 15.

Late Ayyubid – Mamluk (Late 12<sup>th</sup> – 14<sup>th</sup> century AD).

36.

J13-Dab-10-35 and Dab-29-6

Rim, fragmented.

Fig. 36.

Munsell: core: 5YR 6/4; int.: 7.5YR 7/3; ext.: 7.5YR 6/6; deco.: 10R 4/4.

Diam.: 46; H.: 9.9; L.: 17; T. min.: 0.8; max.: 1.5.

Bowl with convex sloping neck/body; flattened, out turned rim; ledge int., circulating rim; deco. int.: broad horizontal line circulating rim, geometric triangular pattern at upper body; geometric spirals following a broad pointed line at

lower body; deco. ext.: two horizontal lines, straight and wavy, circulating rim; rim: crosshatched pattern framed by two horizontal lines.

*References:* deco.: Franken (1975), p. 197, fig. 16-20; shape: Thuesen (1988), p. 237, no.4 and p. 236, no. 4; Lichtenberger, Raja and Sørensen (forthcoming), fig. 40. Late Ayyubid – Mamluk (Late 12<sup>th</sup> – 14<sup>th</sup> century AD).

*Bases*

37.

J13-D-9-2 and Eb-17-1

Base, fragmented.

Fig. 37.

Munsell: core: 2.5YR 6/6; int.: 7.5YR 7/6; ext.: 7.5YR 7/4; deco.: 7.5YR 3/2.

Diam.: 16; H.: 3.1; L.: 7.2; T. min.: 0.8; max.: 2.6.

Bowl/plate; base: flattened, concave at centre; but sloping body; piercing in base; deco. int.: 2x4 dark lines framing the centre; centre: spiral patterns, triangular and circular; ext.: undecorated. Base: three black painted triangles, part of a star form.

*References:* deco.: Tholbecq (1997-1998) p. 164, fig. 16; Avissar (2005), p. 74 fig. 2.24 no. 6; shape: Franken (1975) p. 193, fig. 25-26; Lichtenberger, Raja and Sørensen (forthcoming), fig. 44.

Late Ayyubid – Mamluk (Late 12<sup>th</sup> – 14<sup>th</sup> century AD).

38.

J13-D-9-9

Base, fragmented.

Fig. 38.

Munsell: core: 10R 2/1; int.: 10R 3/3; ext.: 10R 4/6; deco.: 10YR 8/2.

Diam.: 5.5; H.: 6.2; L.: 12.7; T. min.: 0.9; max.: 1.2.

Jug, base concave at centre. Globular body; deco. int.: chequered pattern flanked by two vertical wavy lines. Deco. very poorly preserved. Most likely from a jug similar to cat. no. 40.

*References:* Tolbecq (1997), p. 162 no. 8; Walmsley (2008), p. 134, fig. 27.

Late Ayyubid – Mamluk (Late 12<sup>th</sup> – 14<sup>th</sup> century AD).

39.

J13-Eab-8-9

Base, fragmented.

Fig. 39.

Munsell: core: 7.5YR 7/3; int.: 2.5YR 7/6 and 5YR 8/3; ext.: 7.5YR 7/3; deco.: 10R 3/1 and 10R 3/4.

Diam.: 9.9; H.: 3.9; L.: 6.7; T. min.: 1.2; max.: 3.3.

Bowl with disk base; deco. int.: chequered triangular pattern, circulating a squared spiral at centre. Two horizontal lines, straight and wavy; ext.: broad dark line circulating base and lower body; ext.: three black painted triangles, part of a star form.

*References:* Franken (1975), p. 193, fig. 3; Lichtenberger,

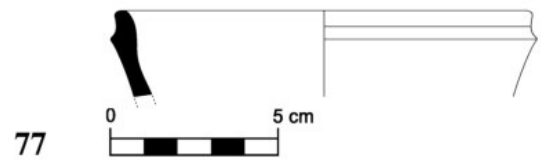
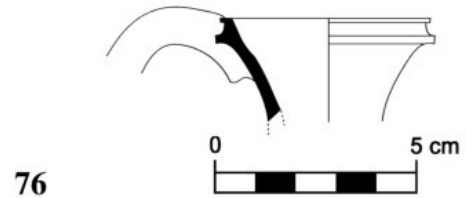
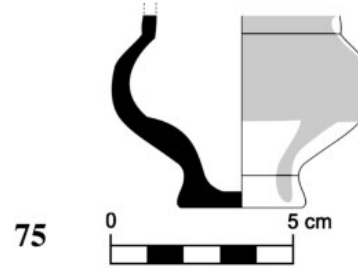
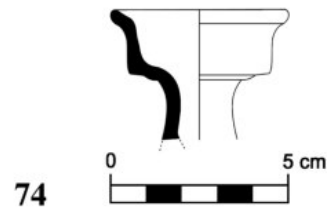
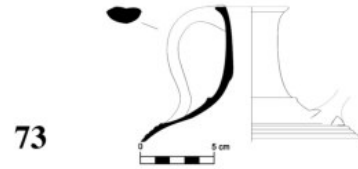
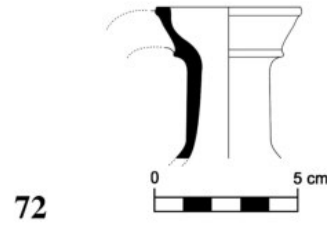
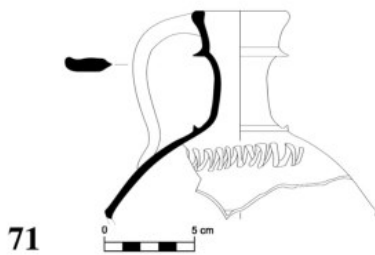
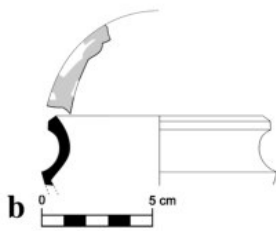
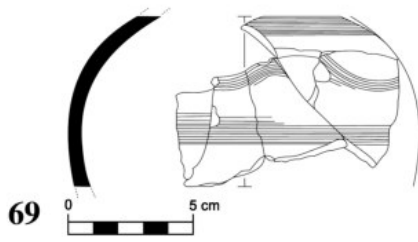
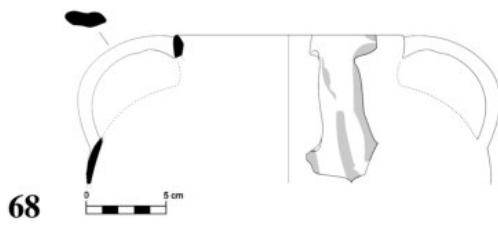
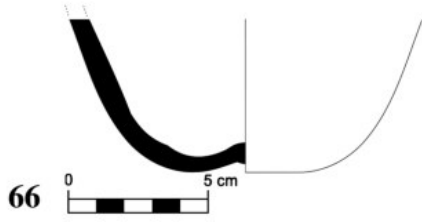



Raja and Sørensen, fig. 44; Walmsley (1997-98), fig. 10 no. 3; Avissar and Stern (2005), no. II.1.4.1 (fig. 3), II.4.4.1 (fig. 2); Avissar (2005), p. 74, fig. 2.24 no. 6.

Late Ayyubid – Mamluk (Late 12<sup>th</sup> – 14<sup>th</sup> century AD).

*Body*

40.

J13-Da-9-10,11 and Da-10-36

Body, fragmented.

Fig. 40.

Munsell: core: 2.5YR 4/8 and 7.5R 3/1 and 7.5R 5/8; int.: 10R 5/4 and 7.5 5/3; ext.: 2.5YR 5/8; deco.: white page: N/9.5 and white page 7.5YR 1/9 and 10R 4/4.

Diam. max: 14.5; H.: 20.3; L.: 14.5; T. min.: 0.5; max.: 1.3.

Jug with outwards sloping neck and globular body; handle not preserved, but attachments at mid neck and body are visible. Sandwich core at upper part of vessel, but not in the lower part; deco.: ext.: four sections of decorations at neck, shoulder and body; geometric patterns; pointed lines circulating shoulder, square geometric pattern at neck and mid body; chequered pattern at lower part of body. Deco. poorly preserved.

*References:* deco. and shape: Milwright (2001), p. 19, fig. 5; Walmsley (2008), p. 134, fig. 27; Walker (2009), p. 114 no. 9, Tholbecq (1997), p.162, no. 1; shape: Walker (2012), p. 584, fig. 4.24 no. 1.

Late Ayyubid – Mamluk (Late 12<sup>th</sup> – 14<sup>th</sup> century AD).

### **Lamps (SKr)**

*Rims*

41.

J13-Gb-12-107

Rim and filling-hole, fragmented.

Fig. 41.

H.: 1.4; L.: 2.3; T.: 0.2 – 0.4.

Munsell: core: 7.5YR 8/4; int.: 7.5YR 8/4; ext.: 7.5YR 7/4; Slip: 2.5YR 4/6.

Moulded lamp with rounded body; hard fired; deco.: upper ext. surface, ovules, dots and curving lines; traces of a slip.

*References:* Loeschke (1919), typus VIII; Kennedy (1963), type 5, plate XXII, no. 507-508; Rosenthal and Sivan (1978), Broneer type XXV, no. 138, 145, 155, 157-159, 164; Bailey (1988), Q1952-1956; Kenkel (2012), groupe 14, La 50, 58.

Roman (Late 1<sup>st</sup> – late 3<sup>rd</sup> century AD).

42.

J13-Gd-28-12

Rim, nozzle and wick-hole, fragmented.

Fig. 42.

H.: 2.6; L.: 3.6; T.: 0.4 – 0.5.

Munsell: core: 2.5YR 6/6; int.: 2.5YR 6/4; ext.: 1.5 YR 6/6; slip: 2.5YR 3/6.

Moulded Gerasa lamp; triangular nozzle; hard fired;

sporadic, small lime inclusions; square rim; traces of fire int. and around wick-hole; deco.: upper ext. surface, relief in the shape of straight and curving grooves and oval-shaped dots; covered with slip.

*References:* Rosenthal and Sivan (1978), no. 391-393; Kehrberg (1989), no. 15-21.

Roman (2<sup>nd</sup> century AD).

43.

J13-Ha/Ha1-13-28

Rim and filling-hole, fragmented.

Fig. 43.

H.: 1.5; L.: 4.6; T.: 0.2 – 0.6.

Munsell: core: 7.5YR 6/2; int.: 7.5YR 6/3; ext.: 5YR 5/4 and 5YR 5/1.

Moulded Gerasa lamp with round body; hard fired; sporadic, small lime and quartz inclusions; rim is square; traces of fire on int. and ext. surfaces; deco.: upper ext. surface, relief in the shape of curving lines, a vine leaf and a grapevine; partially preserved carinated volute.

*References:* Rosenthal and Sivan (1978), no. 391-393, esp. no. 391; Kehrberg (1989), no. 15-21.

Roman (2<sup>nd</sup> century AD).

44.

J13-Ec-13-47

Rim, filling-hole and wick-hole, fragmented.

Fig. 44.

Diam. max (rim): 2.2; H.: 1.6; L.: 5; T.: 0.3 – 0.7.

Munsell: core: 5YR 7/4; int.: 5YR 6/4 and 5YR 3/1; ext.: 5YR 7/4; slip: 5YR 5/6.

Moulded lamp with round to slight oval body; hard fired; sporadic, small lime inclusions; rim is square; int. and ext. traces of fire; deco.: upper ext. surface, relief in the shape of pointed and curving lines, dots and a circle; traces of slip.

*References:* Da Costa (2001), fig. 5; Kehrberg (2001), fig. 5, a-b; Kenkel (2012), groupe 18, variante B, La 88-89.

Byzantine (4<sup>th</sup> – 6<sup>th</sup> century AD).

45.

J13-Dab-29-7

Rim and filling-hole, fragmented.

Fig. 45.

H.: 1.6; L.: 4.3; T.: 0.25 – 0.7.

Munsell: core: 7.5YR 6/6; int.: 7.5YR 6/6; ext.: 7.5YR 6/6.

Moulded “candlestick” lamp with oval body; hard fired; small to medium, frequent lime inclusions; rim is square to round; deco.: upper ext. surface, relief in the shape of curving and oblique, ellipse-shaped lines.

*References:* Kennedy (1963), pl. XXVI, no. 658-659; Rosenthal and Sivan (1978), no. 475-485; Ball *et al.* (1986), pl. V, 14-15; Scholl (1986), group I, nos. 1; Zayadine (1986), pl. VI, 1, 4; Da Costa (2001), fig. 3, 5.

Byzantine – Umayyad (5<sup>th</sup> – early 8<sup>th</sup> century AD).

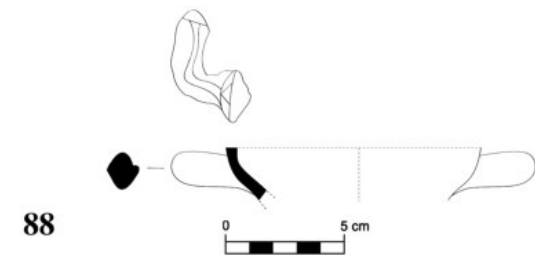
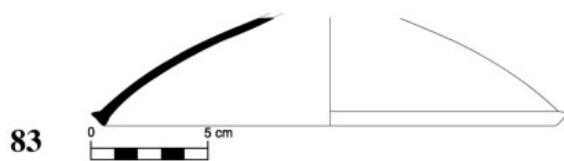
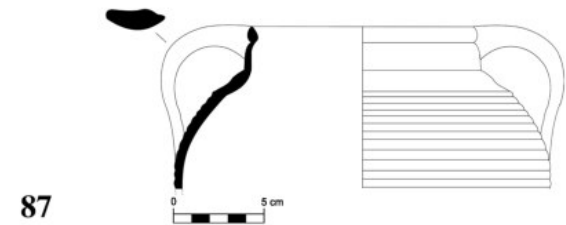
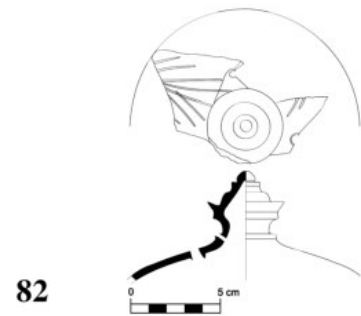
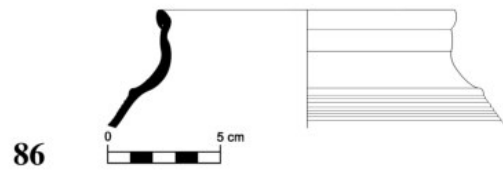
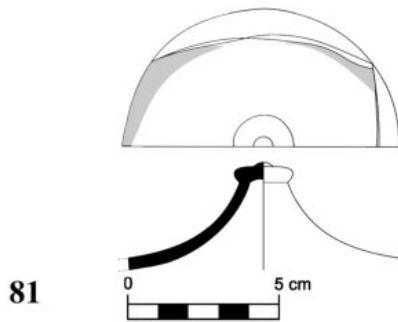
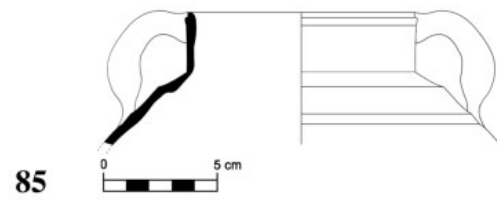
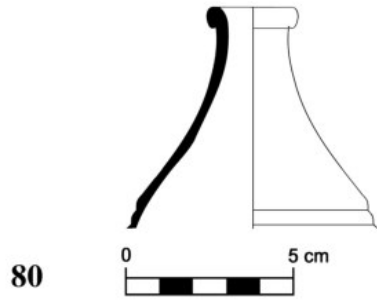
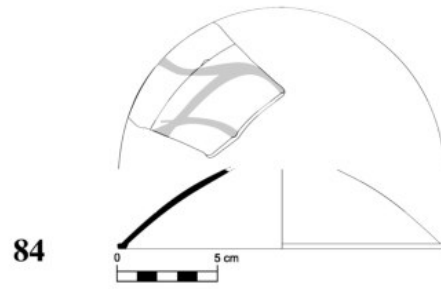
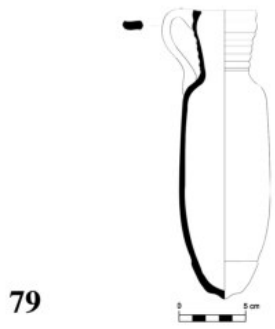

46.

J13-Ec-13-21 and 27

Rim, filling-hole, wick-hole and handle, fragmented.

Fig. 46.

H.: 2.4; L.: 7; T.: 0.2 – 0.5.

Munsell: core: 5YR 5/6; int.: 5YR 6/4; ext.: 7.5YR 7/4.

Moulded Jerash lamp with teardrop-shaped body; handle is raised and curved; hard fired; rim is square to round; traces of fire around wick-hole; deco.: upper ext. surface, relief in the shape of curving and oblique lines, circles, dots and a cross.

*References:* Ball *et al.* (1986), pl. V, no. 16-15; Scholl (1986), group II, nos. 3.

Late Byzantine – Umayyad (Late 6<sup>th</sup> century – late 7<sup>th</sup> century AD).

47.

J13-Ed-19-6 and J13-Ed-20-24

Rim, filling-hole and base, fragmented.

Fig. 47.

H.: 3.4; L.: 7.6; T.: 0.3 – 0.6.

Munsell: core GLEY1 4/N; int.: GLEY1 4/N; ext.: GLEY1 5/N.

Moulded Jerash lamp with oval body; hard fired; frequent, small black and lime inclusions; rim is square; shallow ring-stand; deco.: upper ext. surface, relief in the shape of curving, straight and oblique lines, circles and dots; lower ext. surface, relief in the shape of a circle.

*References:* Scholl (1986), group II; Lichtenberger, Raja and Sørensen (forthcoming), no. 50.

Late Byzantine – Umayyad (Late 6<sup>th</sup> century – late 7<sup>th</sup> century AD).

48.

J13-Fd-40-11

Almost intact.

Fig. 48.

H.: 3.5; L.: 10.6; T.: 0.2 – 2.3.

Munsell: core: 10 YR 4/2; int.: 10YR 4/2; ext.: 10YR 4/2 and 2.5YR 5/4.

Moulded Jerash lamp with teardrop-shaped body; handmade zoomorphic handle; hard fired; frequent, small lime inclusions; rim is square; shallow ring-stand; int. and ext. traces of fire; dark traces of fire around wick-hole; deco.: upper ext. surface, relief in the shape of curving, straight and oblique lines, circles, dots and a cross; lower ext. surface, relief in the shape of circles and curving lines.

*References:* Ball *et al.* (1986), pl. V, fig. 19; (1989), no. 25-26; Scholl (1986), group III, nos. 4; Zayadine (1986), pl. VI, 2-3, 5-12; Lichtenberger, Raja and Sørensen (forthcoming), no. 53.

Late Byzantine – Umayyad (Late 6<sup>th</sup> century – middle of the 8<sup>th</sup> century AD).

49.

J13-Fb-40-111

Rim, base, handle and filling-hole, partially intact.

Fig. 49.

H.: 4.2; L.: 5.8; T.: 0.2 – 1.3.

Munsell: core: 7.5YR 5/1; int.: 7.5YR 5/1; ext.: 7.5YR 5/1 and 7.5YR 7/3.

Moulded Jerash lamp with oval body; handmade zoomorphic handle; hard fired; frequent, small to medium lime inclusions; rim is square; shallow ring-stand; traces of fire on upper ext. surface; deco.: upper ext. surface, relief in the shape of curving and oblique lines, circles, dots and a cross; lower ext. surface, relief in the shape of circles, oblique and curving lines.

*References:* Ball *et al.* (1986), pl. V, fig. 19, 21; (1989), nos. 25-26; Scholl (1986), group III; Zayadine (1986), pl. VI, 2-3, 5-12.

Late Byzantine – Umayyad (7<sup>th</sup> century – middle of the 8<sup>th</sup> century AD).

#### *Bases*

50.

J13-Ha/Ha1-13-54

Base, fragment.

Fig. 50.

Diam. (base): 6; H.: 1.4; L.: 4.7; T.: 0.5 – 0.9.

Munsell: core: 7.5YR 8/3; int.: 2.5YR 3/3; slip: 10R 5/8.

Moulded lamp with round body; hard fired; sporadic, small grey/brown stone and lime inclusions; shallow ring-stand; deco.: lower ext. surface, circular groove; relief in the shape of slightly curving lines; surface covered with slip.

*References:* McNicoll *et al.* (1992), pl. 81, no. 1-3.

Late Hellenistic – early Roman (1<sup>st</sup> century BC).

51.

J13-Fa-17-8

Base, fragmented.

Fig. 51.

Max. Diam. (base): 1.8; H.: 0.9; L.: 3.8; T.: 0.1 – 0.2.

Munsell: core: 5YR 7/6; int.: 5YR 7/6; slip: 2.5 YR 4/6.

Moulded lamp with round body; slightly concave base; hard fired; sporadic, small stone and lime inclusions; deco.: lower ext. surface, circular groove; surface covered with slip.

*References:* Loeschcke (1919), type VIII; Rosenthal and Sivan (1978), Broneer type XXV, no. 387-390; Hadad (2001), type 7; Kenkel (2012), gruppe 13.

Roman (1<sup>st</sup> – 3<sup>rd</sup> century AD).

#### *Handle*

52.

J13-Dab-16-9

Handle, fragmented.

Fig. 52.

H.: 2.2; L.: 1.7; T.: 1.2 – 1.5.

Munsell: core 1: 2.5YR 4/1; core 2: 2.5YR 5/6; ext.:

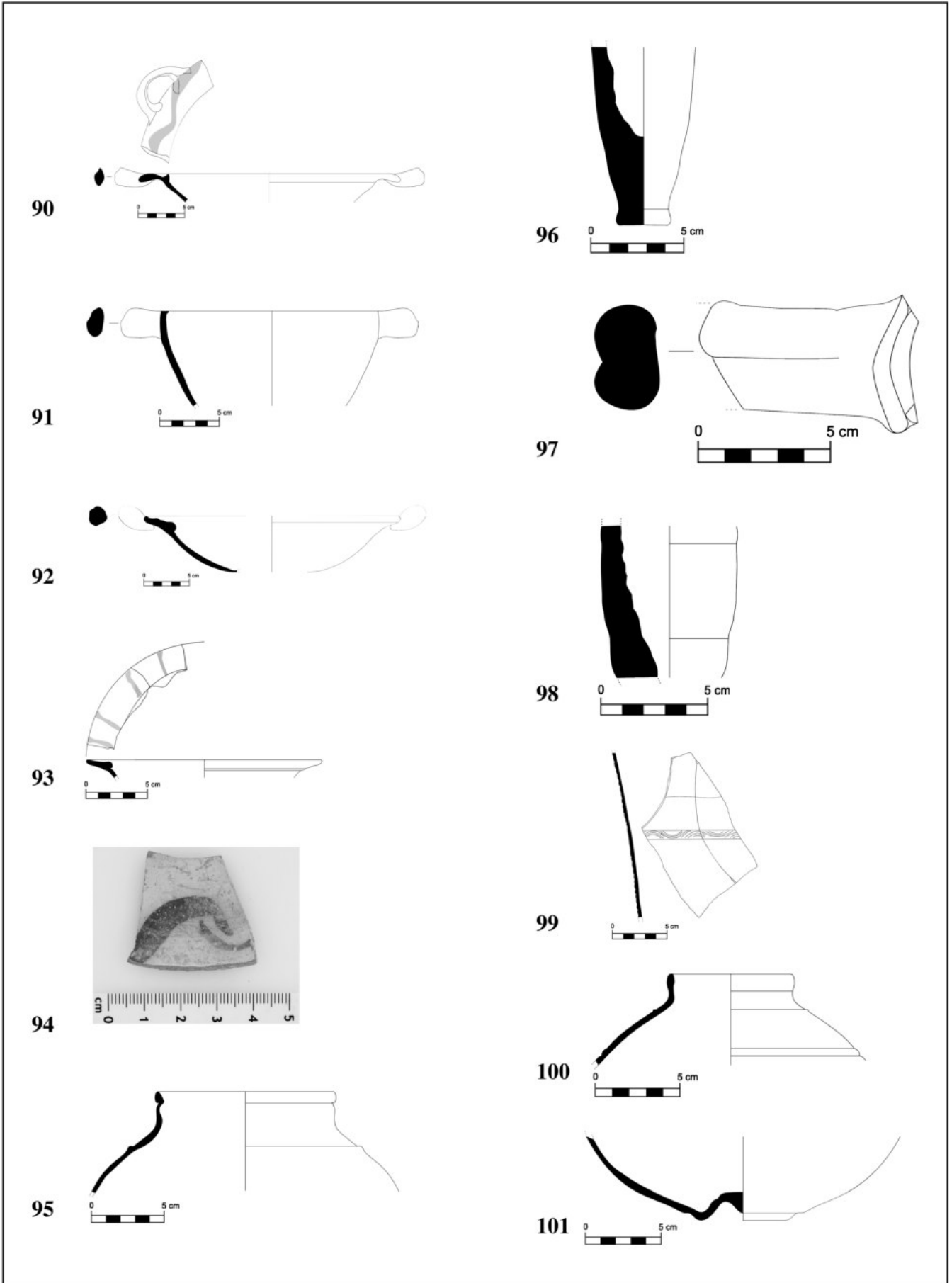

2.5YR 5/6.

Handmade zoomorphic handle; hard fired; small, frequent lime inclusions; deco.: upper ext. surface, straight grooves below the head.

*References:* Scholl (1986), group III-V.

Late Byzantine – Umayyad (Late 6<sup>th</sup> century – mid 8<sup>th</sup> century AD).

### **Lanterns (SKr)**

#### *Rims*

53.

J13-Ed-18-67-70

Rim, handle and shoulder, fragmented.

Fig. 53.

Diam. (max): 18; H.: 19.3; L.: 18; T.: 0.4 – 0.8.

Munsell: core: 10YR 7/4; int.: 10YR 7/4; ext.: 2.5YR 7/6.

Handle is round, clear cut circle of terracotta; handmade attachment of handle; shoulder bends inwards; part of the knife-cut opening for the lamp; medium-sized holes have been cut from the ext.; hard fired; wheel made; medium levigation; sporadic, small lime and quartz inclusions; traces of fire around lamp hole; horizontal, carinated lines on neck and shoulder.

*References:* Piazza (1983-1984), fig. 46; Gawlikowski and Musa (1986), no. 33; Uscatescu (1996), fig. 31, fig. 77, 437, fig. 101, 701; Lichtenberger, Raja and Sørensen (forthcoming), no. 59, 61 and 63.

Late Byzantine – Umayyad (5<sup>th</sup> century – late 7<sup>th</sup> century AD).

#### *Base*

54.

J13-Gb-9-5+16

Base, fragmented.

Fig. 54.

Diam. (base): 12; H.: 4.5; L.: 10.1; T.: 0.3 – 0.7.

Munsell: core: 2.5YR 5/8; int.: 2.5YR 6/8; ext.: 2.5YR 6/8.

Base is flat and round; body bends outwards; medium-sized holes have been cut from the ext.; hard fired; wheel made; medium levigation; covered with line int. and ext.; frequent, small to medium lime inclusions.

*References:* Piazza (1983-1984), fig. 46; Gawlikowski and Musa (1986), no. 33; Uscatescu (1996), fig. 31; Lichtenberger, Raja and Sørensen (forthcoming), no. 61 and 63.

Byzantine – Umayyad (5<sup>th</sup> century – late 7<sup>th</sup> century AD).

#### *Body*

55.

J13-Hc-4-8

Shoulder, fragmented.

Fig. 55.

Diam. (shoulder): 15; H.: 2.65; L.: 9; T.: 0.4 – 1.

Munsell: core: 7.5YR 5/4; int.: 7.5YR 6/3; ext.: 10YR 7/3.

Fragment of a shoulder; body bends inwards; small holes have been pierced from the ext.; medium fired; wheel made; medium levigation; frequent, small lime, black and quartz inclusions; rim is pointed; deco.: upper ext. surface, deep grooves in the shape of pointed lines, and circles enclosing central pointed lines.

*References:* Uscatescu (1996), fig. 76, 407-409, 411, 413; fig. 77, 436 (in terms of decorated ext. surface); Bonifay (2004), fig. 168, p. 300; Ferrazzoli *et al.* (2010), fig. 3, no. 20-27, fig. 4, no. 29-36; Lichtenberger, Raja and Sørensen (forthcoming), no. 56.

Late Byzantine – Umayyad (6<sup>th</sup> century – late 7<sup>th</sup> century AD).

### **Table Wares (PE; SBr)**

#### *Bowls*

#### *Rims*

56.

J13-Ha-13-11A

Rim, fragmented.

Fig. 56.

Munsell: core: GLEY26/10B; int. and ext.: GLEY17/10Y; 2.5Y 2,5/1; 2.5Y 6/3.

Diam. (rim): 24; H.: 6.1; L.: 10.9; W. (rim): 1.2; T. (max.): 0.5; (min.): 0.3.

Bowl, hard-fired and rather finely levigated clay.

*References:* form: Kraeling (1938), p. 562-563, fig. 41, no. 21; p. 569, fig. 46, no. 31.

Roman (1<sup>st</sup> century AD).

57.

J13-Ha/a1-13-59

Rim and base, intact profile.

Fig. 57.

Munsell: core: 5YR 4/3; int.: 5YR 5/3; ext.: 5YR 5/2.

Diam. (base): 3.46 (rim): 13; H.: 3.6; L.: 12.1; T. (max.): 0.5; (min.): 0.2.

Bowl, hard-fired and medium levigated clay.

*References:* Lapp (1961), p. 180, J Qumrân II.

Roman (1<sup>st</sup> century AD).

58.

J13-Ga-12-25

Rim and body, fragmented.

Fig. 58.

Munsell: core: 2.5YR 6/6; ext.: 2.5YR 7/8; slipped int.: 2.5YR 6/8.

Diam. (rim): 22; (base): 19.5; H.: 3.5; L.: 18.5; T. (max.): 0.6; (min.): 0.5.

Bowl/large plate; hard fired, rather coarse clay with some air pockets.

*References:* form: Uscatescu (1996), p. 243, 17, fig. 37, 17; Hayes (1972), ARS Form 181.

Roman (2<sup>nd</sup> half of 2<sup>nd</sup> – 1<sup>st</sup> half of 3<sup>rd</sup> century AD).

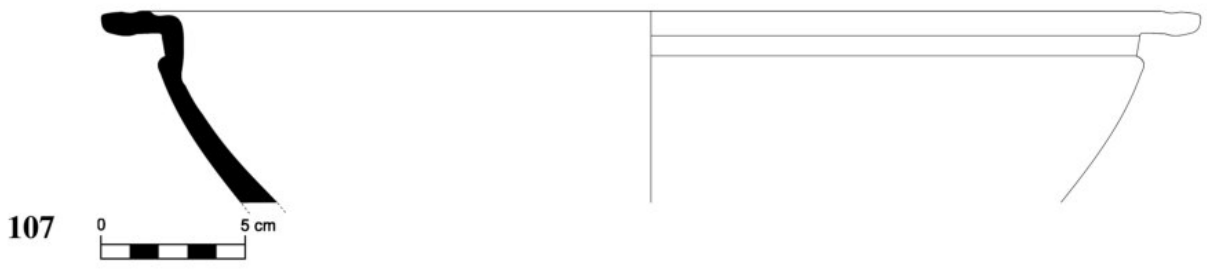
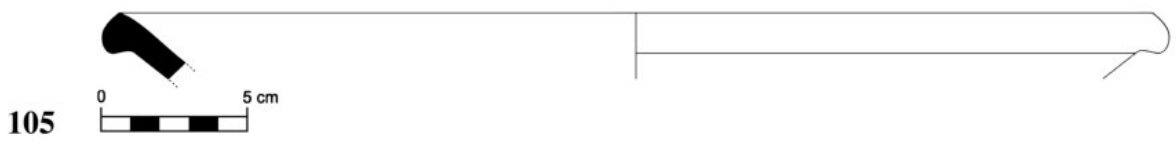
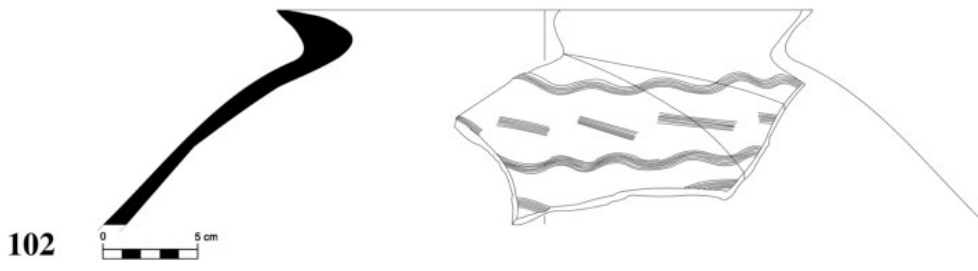

59.

J13-Ga-12-24

Rim, base and body, almost intact.

Fig. 59.

Munsell: core1: 2.5YR 6/8; core2: 2.5YR 6/4; int.: 10R 6/8 + 5/6; ext.: 5YR 7/6, 7/4 + 10R 5/4.

Diam. (rim): 30; (base): 26; H.: 4.6; L.: 30; T. (max.): 1.1; (min.): 0.6.

Bowl/large plate, intact profile, hard fired, medium – finely levigated clay.

*References:* form: Uscatescu (1992), p. 243, fig. 37; Hayes (1972), ARS Form 181.

Roman (2<sup>nd</sup> half of 2<sup>nd</sup> – 1<sup>st</sup> half of 3<sup>rd</sup> century AD).

60.

J13-Ha/a1-13-57

Rim, fragmented.

Fig. 60.

Munsell: core1: 7.5YR 7/4; core2: 2.5YR 6/8; int.: 5YR 7/6; ext. 5YR 6/4.

Diam. (rim): 26; H.: 4.5; L.: 13.3; T. (max.): 1; (min.): 0.4.

Bowl, hard-fired and medium levigated clay.

*References:* Gawlikowski and Musa (1986), p. 144, fig. 5, no. 4.

Byzantine (5<sup>th</sup> – 6<sup>th</sup> century AD).

61.

J13-Ha/a1-14-6

Rim, fragmented.

Fig. 61.

Munsell: core1: 10YR 4/1; core2: 2.5YR 6/8; int.: 2.5YR 6/8; ext.: 2.5YR 6/8+2.5YR 4/2.

Diam. (rim): 20; H.: 3; L.: 6.4; T. (max.): 1.3; (min.): 0.4.

Bowl, hard-fired and medium levigated, well settled clay.

*References:* Gawlikowski and Musa (1986), no. 26, fig. 7.2; resembles: Hayes 1972, LRC Form 3.

Byzantine (2<sup>nd</sup> half of the 5<sup>th</sup> century AD).

62.

J13-Hc-3-8

Rim, fragmented.

Fig. 62.

Munsell: core: 10R 6/8; int. and ext. slipped: 10R 5/8.

Diam. (rim): 22; H.: 3.4; L.: 3.4; W.: 1.3; T. (max.): 0.7; (min.): 0.6.

Bowl, flat outwards folded rim; hard-fired and very finely levigated clay.

#### *Orange Ware*

63.

J13-Ha/Ha1-13-30

Rim, fragmented.

Fig. 63.

Munsell: core: 10R 6/8; int.: 10R 7/6; ext.: 10R 6/6.

Diam.: 28; H.: 3.05; L.: 9; T. min.: 0.4; max.: 0.5.

Bowl with out-folded rim, neck flaring inwards; distinct convex shoulder, steep body shape.

Uscatescu (1996) p. 339, no. 343; Gawlikowski-Musa (1986), no. 26, fig. 7, 2; resembles: Hayes (1972) LRC, Form 3.

Byzantine (5<sup>th</sup> – 6<sup>th</sup> century AD).

#### *Reddish/Red Brown Ware*

64.

J13-Ga-12-35

Rim, fragmented.

Fig. 64.

Munsell: core: 2.5YR 5/4; int.: 2.5YR 6/6; ext.: 2.5YR 4/4.

Diam.: 24; H.: 4.2; L.: 8.6; T. min.: 0.4; max.: 0.6.

Bowl with flattened out turned rim; very distinct shoulder; vertically attached, carinated handle, attached over rim.

*References:* Uscatescu (1996), p. 286, Grupo XVI fig. 5, (figura 16); Negev (1986), p. 98, fig. 821, 822; Gaspar (2009), p. 663, fig 19, no. 29.

Late Roman.

65.

J13-Dab-17-22

Rim, fragmented.

Fig. 65.

Munsell: core: 2.5YR 5/6 and 2.5YR 3/2; int.: 2.5YR 6/8; ext.: 2.5YR 5/6.

Diam.: 18; H.: 4.3; L.: 4.5; T. min.: 0.33; max.: 0.9.

Bowl with high, straightened neck and rounded rim; deco.: incised wavy line at ext.

*References:* Uscatescu (2001), p. 75, no. 1, 2; Uscatescu (1996), p. 303, fig. 33 and p. 338 no. 338 and p. 370 no. 687; Magness (1993), p. 194, fig. 1, 3.

Late Byzantine (late 6<sup>th</sup> century – 1<sup>st</sup> half of 7<sup>th</sup> century AD).

#### *Bases*

##### *Reddish/Red Brown Ware*

66.

J13-Ed-18-33

Base, intact profile.

Fig. 66.

Munsell: core: 2.5YR 6/6; int.: 2.5YR 6/8; ext.: 2.5YR 6/8.

Diam.: 10; H.: 4.6; L.: 4.4; T.: min. 0.3; max. 0.5.

Bowl/cup. Omphalos base.

*References:* Uscatescu (1996), p. 338, no. 329.

Date: Byzantine.

#### *Plate*

##### *Rim*

67.

J13-Gf-30-36

Rim and 'spout', fragmented.

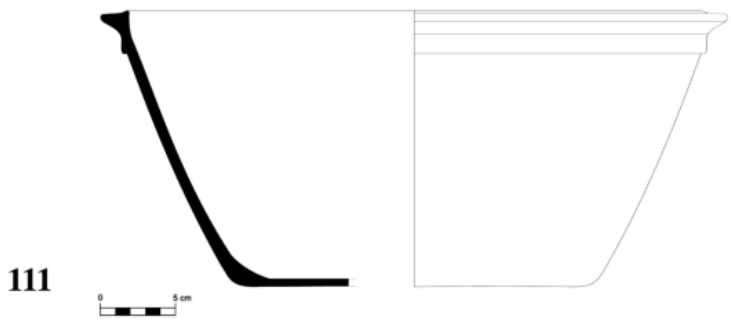
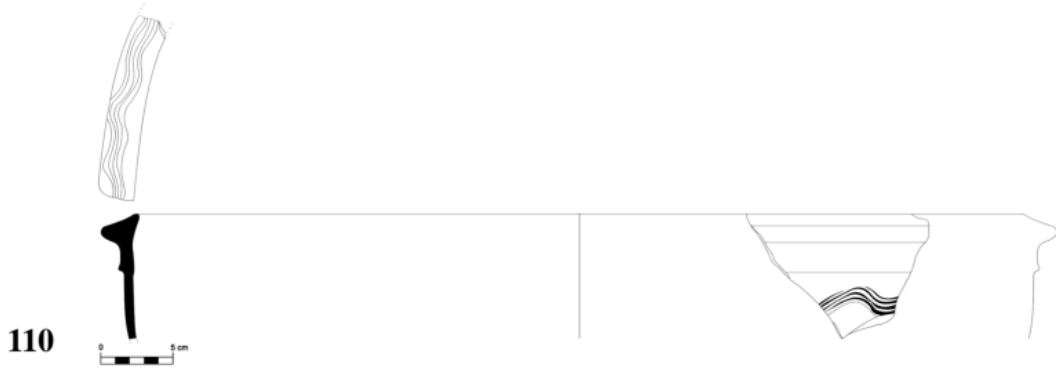



Fig. 67.

Munsell: core1: 10R 4/1; core2: 10R 5/6; int.: 10R 5/6; ext.: 10R 5/6.

Diam. (rim): 28; H.: 1.7; L.: 6.8; T. max.: 0.7; min.: 0.4. Plate, hard-fired, medium levigated, well settled clay. A little 'spout' (not wider than a thumb) on rim; the spout is not indicated in the drawing.

*References:* form, without the 'spout': Rasson (1986), fig. 17, 2; Hayes (1972), ARS Form 181.

Roman (2<sup>nd</sup> half of the 2<sup>nd</sup> century – 1<sup>st</sup> half of the 3<sup>rd</sup> century AD).

#### *Jars*

##### Rim

##### *Reddish/Red Brown Ware*

68.

J13-Dab-13-23

Rim, fragmented.

Fig. 68.

Munsell: core: 2.5YR 4/8; int.: 2.5YR 5/8; ext.: 2.5YR 4/6; deco.: White page N/9.

Diam.: 14.6; H.: 9.8; L.: 4.3; T.: 0.6.

Jar with a rounded rim; rim fragment with intact handle attached; vertical set carinated handle, over folded rim. Body fragment preserved at handle; deco.: Three white vertical lines at handle.

*References:* Ball (1986), p. 354, no. 1.

Late Roman – Byzantine.

##### Body

69.

J13-Ed-19-23

Fig. 69.

Body, fragmented.

Munsell: core: 5Y 8/1; int.: 10YR 8/2; ext.: 5Y 8/1.

Diam. max: 14; H.: 6.8; T.: max.: 0.65; min.: 0.6.

Five joining pieces of a closed vessel of a cream coloured fabric. Softly fired, few lime and small stone inclusions. Deco.: combed horizontal and wavy lines running around the vessel; probably corresponds to one of the cream wares occurring in the 8<sup>th</sup> century AD. According to Walmsley: "Ware 7".

*References:* Ware: Whitcomb (2008), p. 490; Walmsley (1995), p. 661.

Abbasid (?).

##### *Painted Buff Ware*

##### Rim

70.

J13-D-9-8

Fig. 70a-b.

Rim, base and body, fragmented – rim and base do not join.

Munsell: core: 5YR 6/8; int.: 5YR 7/6 and 7.5YR 7/6; ext.: 5YR 7/6 and 5YR 5/8; deco.: 2.5YR 4/4 and 2.5YR

3/4.

Diam. rim: 10, base: 20; H.: rim 2.8, base: 7.5; L.: rim: 5.5, body: 12.2; T.: max: 0.5, min.: 0.2.

Flattened rim, omphalos base, deco.: irregular sprays of dark brown paint on ext. of body and on lip. Rim and body do not join, but may belong to the same vessel – probably a jug or a jar.

*References:* Avissar and Stern (2005), p. 111-112, fig. 46.1-2 (Mamluk); Smith (1973), p. 237-238, pl. 71 no. 479, 480, 928 (Abbasid); McNicoll (1992), p. 194, pl. 125.4 (Fatimid-Mamluk)

Ayyubid – Mamluk.

#### *Jugs*

##### Rims

71.

J13-Dab-13-7

Rim, fragmented.

Fig. 71.

Munsell: core: 2.5YR 5/8 and 2.5YR 4/1; int.: 2.5YR 5/8 and 2.5YR 4/1 and 2.5YR 4/2; ext.: 2.5YR 5/8 and 2.5YR 4/1 and 2.5YR 4/2.

Diam.: 5.4; H.: 11.4; L.: 10.2; T. min.: 0.3; max.: 0.4.

Jug; rim, neck and handle intact. Rounded inwards folded rim; rim and upper neck flaring outwards. Ledge secondarily attached at upper part of neck and shoulder. Globular body shape. Rocker pattern impressed at upper body/shoulder. Flattened, vertical handle; probably a spouted jug.

*References:* Shape: Pierobon (1978-1980), p. 102, fig. 8 – Je 5071; Canivet (1992), fig. 5, no. 1, 2, 3; deco.: Canivet (1992), fig. 9, no. 2; fig. 5, no. 36; Lichtenberger, Raja, Sørensen (forthcoming) no. 81-82.

Late Byzantine (Late 6<sup>th</sup> century AD – 1<sup>st</sup> half of the 7<sup>th</sup> century AD).

72.

J13-Hc-5-4

Rim, fragmented.

Fig. 72.

Munsell: core: 10YR 5/2; int.: 10YR 5/1; ext.: 10YR 4/1. Diam.: 5; H.: 5.2; L.: 4.5; T. min.: 0.2; max.: 0.7.

Jug with high funnel shaped neck with flattened out-flaring rim; handle attachment preserved under rim; convex ledge at upper part of neck.

*References:* Ball (1986), p. 356, no. 2; Teichner (2009), p. 984, fig. 6, no. 1.

Late Byzantine (late 6<sup>th</sup> century AD – 1<sup>st</sup> half of the 7<sup>th</sup> century AD).

73.

J13-Ed-18-88

Rim, fragmented.

Fig. 73.

Munsell: core: 2.5YR 6/6; int.: 2.5YR 6/6; ext.: 2.5YR

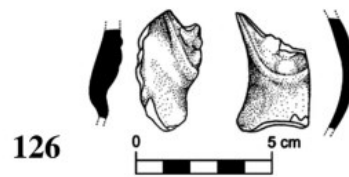
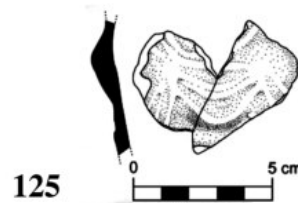
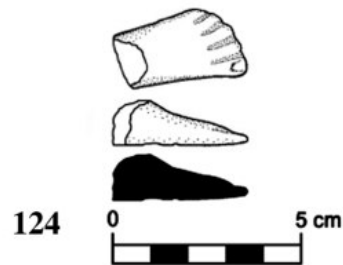
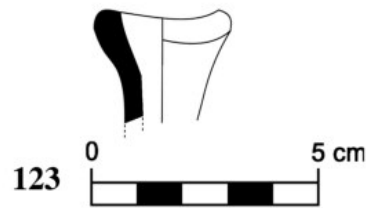
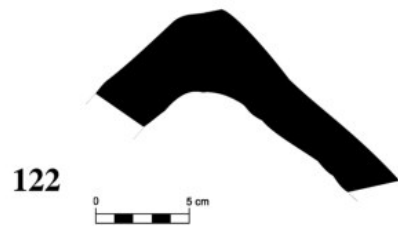
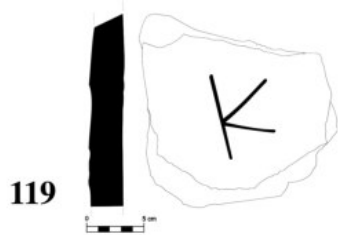
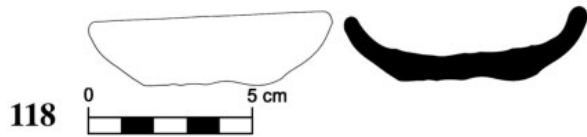
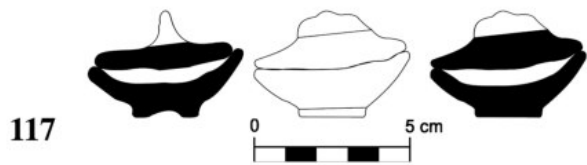

6/6.

Diam.: 5; H.: 9.2; L.: 14.4; T. min.: 0.3; max.: 0.5.

Spouted jug; rim, neck and handle intact, high straightened neck; convex ledge at shoulder; flattened out folded rim; ribbed and globular body; vertical carinated handle folded over lip; spout hole and spout attachment preserved on shoulder.

*References:* Canivet (1992), fig. 5, no. 1, 2, 3, fig. 3, no. 24; Lichtenberger, Raja and Sørensen (forthcoming), fig. 83; Uscatescu (1996), fig. 19, group XXIX, no. 5, fig. 80 no. 483.

Byzantine.

74.

J13-Gb-12-65

Rim, fragmented.

Fig. 74.

Munsell: core: 10R 5/2; int.: 2.5YR 7/6; ext.: 2.5YR 8/6.

Diam.: 5; H.: 3.6; L.: 5; T. min.: 0.35; max.: 0.6.

Jug with a high, narrow neck with funnel shaped mouth; out-flaring, rounded rim and convex ledge at upper part of neck. Most likely at spouted jug.

*References:* Piazza (1983-1984), p. 131, fig. H, no. 52; Berlin (1997), plate 49, no. PW 438; Oweiss (1985), p. 4, no. 27.

Byzantine.

*Base*

75.

J13-Ga-12-40

Base, fragmented.

Fig. 75.

Munsell: core: 5YR 7/3; int.: 2.5YR 6/6; ext.: 7.5YR 8/2; paint: 7.5YR 4/3.

Diam. (base): 3.5; H.: 5.2; L.: 7; T. max.: 0.2; min.: 0.25.

Flat base, closed vessel, hard-fired, but rather coarse clay with air pockets; deco.: paint/slip partly covering the ext. surface.

Not datable

*Reddish/Red Brown Ware*

Rim

76.

J13-Hc-4-12

Rim, fragmented.

Fig. 76.

Munsell: core: 7.5R 4/1 and 10R 5/6; int.: 7.5R 5/6; ext.: 7.5R 4/6.

Diam.: 5; H.: 2.5; L.: 4.3; T. min.: 0.2; max.: 0.6.

Jug with dual flattened rim, out folded. funnel shaped neck sloping outwards; handle attached at rim and neck, over folding the rim. Square, vertically placed handle, two shallow carinations. Sandwich core.

*References:* Walmsley (2008), p. 132 fig. 18.

Late Roman – Byzantine.

*Green Ware*

77.

J13-Ha/a1-20-4

Fig. 77.

Rim, fragmented.

Diam.: 12; H.: 2.5; L.: 4.1; W.: rim 0.6; T.: max: 0.8, min.: 0.4.

Closed shape, rounded rim, probably a neck jug.

*References:* Ware: resembles: Fuller (2011), <http://users.stlcc.edu/mfuller/Area2pottery.html>.

Possibly Abbasid.

78.

J13-Gb-12-82A

Fig. 78.

Rim, fragmented.

H.: 5; L.: 5.6; W.: rim: 0.5; T. max: 0.5, min.: 0.3.

Lip and neck slightly outcurving, irregular oval mouth, probably a neck jug.

*References:* Ware: resembles: Fuller (2011), <http://users.stlcc.edu/mfuller/Area2pottery.html>.

Possibly Abbasid.

*Juglet*

Rim

79.

J13-Ed-18-1X (J13-Ed-18-71)

Juglet, intact.

Fig. 79.

Munsell: core: 2.5YR 6/8; int.: 5YR 5/6 and 5YR 4/2; ext.: 5YR 6/6.

Diam.: rim: 3.6; max.: 6.6; H.: 21.8; T. min.: 0.2; max.: 0.4.

Juglet with high, slightly out-flaring neck, ribbed at ext.; flattened rim sloping inwards. Vertically set carinated handle; handle over folded at rim, and attached at shoulder. Cylindrical body shape, very finely ribbed, almost not visible, rounded base.

*References:* Konrad (2001), p. 177, no. 1; Lichtenberger, Raja and Sørensen (forthcoming), fig. 112.

Late Byzantine (end of the 6<sup>th</sup> century AD – first half of the 7<sup>th</sup> century AD).

*Bottle*

Rim

*Reddish/Red Brown Ware*

80.

J13-Ebd-14-33

Rim, fragmented.

Fig. 80.

Munsell: core: 10R 6/6; int.: 7.5YR 5/4; ext.: 2.5YR 5/4 and 2.5YR 5/1.

Diam.: 2.7; H.: 6.45; L.: 4.7; T. rim: min.: 0.5; max.: 0.6; body: min.: 0.2; max.: 0.35.

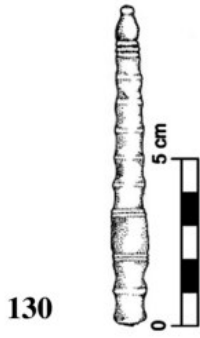
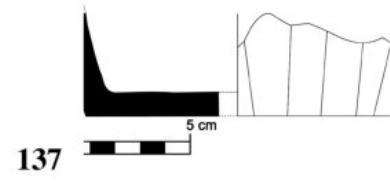
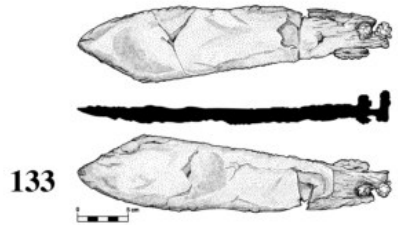
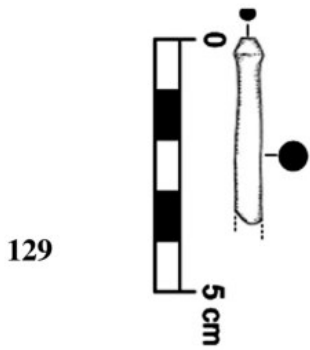
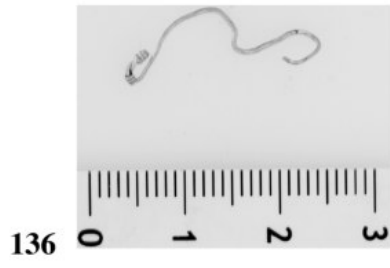
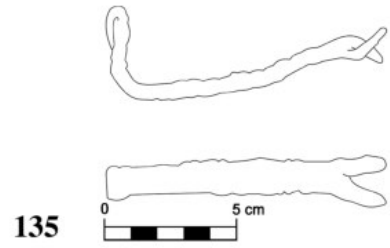
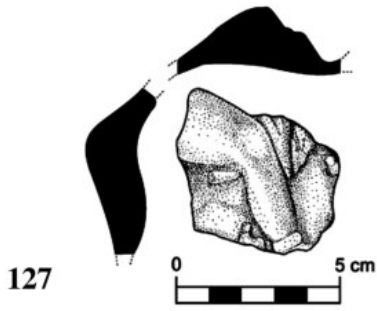

Flask/bottle with rounded out folded rim; ribbed body.

*References:* Uscatescu (1996), p. 348, fig. 78,451.

Late Byzantine.

*Lids*

*Knobs*

*Reddish/Red Brown Ware*

81.

J13-Fa-9-8

Knob, fragmented.

Fig. 81.

Munsell: core: 2.5YR 6/6; deco.: 7.5YR 9/1.

Diam. knob: 1.8; H.: 4.5; L.: 8.4; T.: 0.4.

Rounded raised knob, convex in centre. Dome shaped body. White lines circulating lower ext. part of lid.

*References:* Knob: Uscatescu (1996), p. 311, fig. 41, no. 66; Piazza (1983-1984), p. 103, fig. 1. Je 50 78. Knob and profile: Ball (1986), p. 354, no. 6.

Byzantine.

*Rims*

82.

J13-Ga-12-31

Rim, fragmented.

Fig. 82.

Munsell: core: 2.5YR 6/8; int.: 2.5YR 6/8; ext.: 2.5YR 6/8.

Diam. knob: 4.3; H.: 6; L.: 9.7; T. min.: 0.33; max.: 0.9.

Carinated knob in three levels. Heightened disk shaped lid. Body pierced through at two places. Pierced from the outside before firing; deco.: incised pattern at ext., two leafs. Three horizontal lines circulating knob stem.

*References:* Knob: Uscatescu (1996), p. 346, fig. 76, grupo XVIII, no. 416; p. 310, fig. 40, no. 5; Kenkel (2012), taf. 17.

Byzantine.

83.

J13-Fh-29-9

Rim, fragmented.

Fig. 83.

Munsell: core: 2.5YR 6/8; int.: 2.5YR 5/4; ext.: 10R 5/6; sec. fired: 2.5YR 3/1 and 2.5YR 1/5.

Diam.: 20; 4.5.: 6; L.: 20; T. min.: 0.4; max.: 0.55.

Casserole lid, dome shaped; Flattened, out-folded rim; traces of fire on interior and exterior surfaces.

*References:* Bonifay (2004), p. 222, no. 2; Uscatescu (1996), fig. 76, 346, no. 408; Gerber (2012), p. 385, fig. 3.61, no. 15.

Late Byzantine.

84.

J13-Dab-17-13

Rim, fragmented.

Fig. 84.

Munsell: core: 10R 5/8 and 10R 4/1; int.: 10R 4/1; ext.:

10R 5/4; deco.: 10R 8/3.

Diam.: 16; H.: 3.9; L.: 6.15; T. min.: 0.23; max.: 0.43.

Lid with flattened out turned rim; dome shaped body. Sec. fired at int.; deco.: asymmetric pattern at ext. softly curvy lines.

*References:* Piazza (1983-1984), p. 103, fig. 1. Je 50 78; Canivet (1992), fig. 3, no. 27.

**Cooking Vessels (PE; SBr)**

*Cooking pots*

*Rims*

*Orange Ware*

85.

J13-Gb-12-79

Rim, fragmented.

Fig. 85.

Diam.: 10; H.: 5.9; T.: rim: 0.5; body: min.: 0.2, max.: 0.5.

Munsell: core: 2.5YR 6/6; int.: 2.5YR 6/6; ext.: 2.5YR 6/6.

Cooking pot with a high straightened neck. Rounded rim, slit by a deep ledge under lip. Steep shoulder and indication of a globular body shape. Vertical, pinched handle attached on rim and shoulder. Finger impressions visible at handle.

*References:* Gerber (2012), p. 295, fig. 3.30, no. 20-21; Kenkel (2012), Kt25, tafs. 26 and 63.

Late Roman.

*Reddish/Red Brown Ware*

86.

J13-Fb-40-114

Rim, fragmented.

Fig. 86.

Munsell: core: 2.5YR 5/6 and 2.5YR 4/1; int.: 2.5YR 5/8; ext.: 2.5YR 5/6.

Diam.: 13; H.: 5.2; L.: 7.7; T. min.: 0.15; max.: 0.4.

Cooking pot(?) with out-folded rounded rim; bulge under lip. Convex ledge at shoulder, ribbed at shoulder/body. Sandwich core.

*References:* Kenkel (2012), taf. 41, no. Am 22.1a and Am 22.1b, Canivet (1992), fig. 1, no. 6; Magness (1993), p. 218, fig. 1.

Late Roman/Byzantine.

87.

J13-Fd-40-51

Rim, fragmented.

Fig. 87.

Munsell: core: 2.5YR 5/6; int.: 2.5YR 5/6; ext.: 2.5YR 5/4 and 5YR 5/2 and 10YR 4/1.

Diam.: 12; H.: 8.8; L.:10.6; T. min.: 0.3; max.: 0.6.

Pot with rounded, over folded rim sloping inwards; straight, short neck; ledge at shoulder; ribbed, globular body; vertically placed carinated handle attached at rim and mid body.

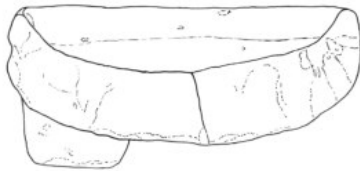

FRONT VIEW

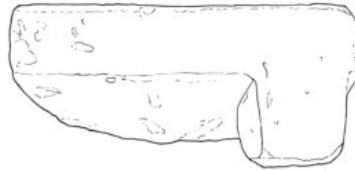

BACK VIEW

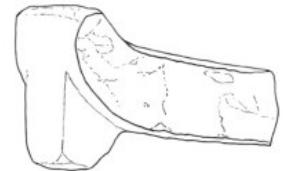

LEFT VIEW

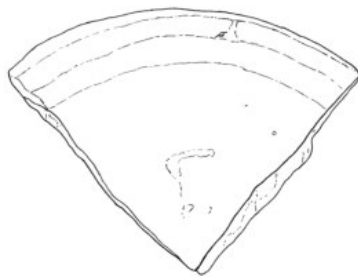

TOP VIEW

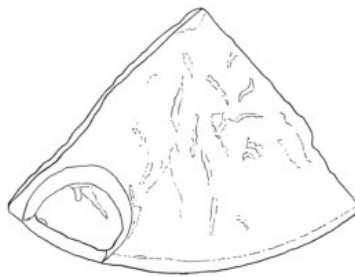

BOTTOM VIEW

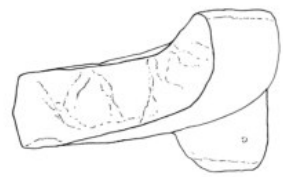

RIGHT VIEW

138

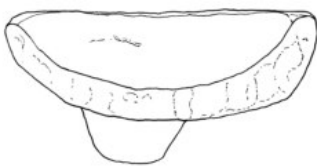

FRONT VIEW

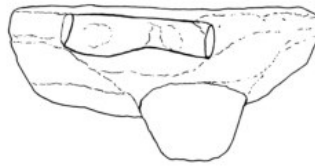

BACK VIEW

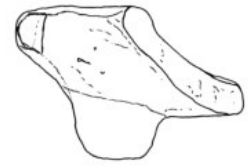

LEFT VIEW



TOP VIEW

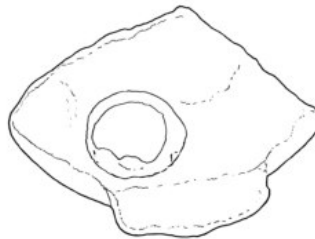

BOTTOM VIEW

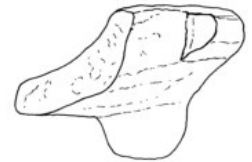

RIGHT VIEW

139

*References:* McNicoll (1992), Pl. 110, no. 1; Canivet (1992), fig. 1, no. 6; Magness (1993), p. 216, fig. 1.

Byzantine.

#### **Casseroles**

##### *Rims*

88.

J13-Ec-27-23

Rim and handle, fragmented.

Fig. 88.

Munsell: core: 2.5YR 4/6; int.: 2.5YR 5/4; ext.: between 10R 5/8 and 7.5YR 6/8.

H.: 2.2; L.: 2.1; W. (rim): 0.5; T. max.: 0.7; min.: 0.5.

Casserole, hard-fired and medium levigated, mottled surface; Cnidian handle type with formed cleft on top of the handle, following the handle curving, as decoration, as well as a seam on the bottom. The curve itself is narrowing while following the handle form until it's almost closed by the potter in the middle of the handle.

*References:* Form: Magness (1993), Casserole form 1.

Late Roman – Byzantine.

##### Reddish/Red Brown Ware

89.

J13-Ed-14-16

Rim, fragmented.

Fig. 89.

Munsell: core: 2.5YR 6/8; int.: 2.5YR 6/8; ext.: 2.5YR 6/8.

Diam.: 18; H.: 5.4; L.: 9.2; T. min.: 0.4; max.: 0.5.

Casserole with flattened rim, flaring inwards; horizontally placed, carinated handle, attached under rim. Dome shaped body.

*References:* Uscatescu (1996), p. 286, fig. 16 grupo XVI no. 1B; Magness (1993), p. 212, fig. 11.

Late Roman – Byzantine.

90.

J13-Fd-40-39

Rim, fragmented.

Fig. 90.

Munsell: core: 2.5YR 6/6; int.: 2.5YR 6/6; ext.: 2.5YR 6/6; deco.: 2.5YR 8/1.

Diam.: 28; H.: 3; L.: 11.4; T. min.: 0.4; max.: 0.5.

Casserole with over-folded, rounded rim, lip flattened and flaring outwards. Ledge at int. rim. Horizontally set, carinated handle raised above the rim but attached under the rim. Dome shaped body. Unevenly fired at rim, ext. deco.: wavy lines at rim.

*References:* Uscatescu (1996), p. 344, fig. 74 no. 395; Canivet (1992), fig. 11, no. 9; Lichtenberger, Raja, Sørensen (forthcoming), fig. 92.

Late Roman – Byzantine.

91.

J13-Fd-40-38

Rim, fragmented.

Fig. 91.

Munsell: core: 2.5YR 6/6; int.: 2.5YR 6/6; ext.: 2.5YR 6/6 and 10YR 2/1.

Diam.: 18; H.: 7.8; L.: 14.9; T. min.: 0.4; max.: 0.5.

Casserole with flattened rim, flaring inwards; horizontally placed, carinated handle, attached under rim. Dome shaped body. Sec. fired at ext.

*References:* Hama vol. II (1990), p. 177, no. 609/611.

Late Byzantine (end of the 6<sup>th</sup> century AD – first half of the 7<sup>th</sup> century AD).

92.

J13-Ed-20-28

Rim, fragmented.

Fig. 92.

Munsell: core: 2.5YR 6/6; int.: 2.5YR 6/6; ext.: 2.5YR 6/6.

Diam.: 28; H.: 6.2; L.: T. min.: 0.4; max.: 0.6.

Casserole with over-folded, rounded rim, lip flattened and flaring outwards; ledge int. on rim. Horizontally placed, carinated handle which is raised above rim but attached under rim; dome shaped body; traces of use over open fire int. and ext. centered at base.

*References:* Profile, not handle Uscatescu (1996), p. 345, fig. 75 grupo XVII no. 400; Lichtenberger, Raja, Sørensen (forthcoming), fig. 94.

Byzantine.

93.

J13-Dab-13-34

Rim, fragmented.

Fig. 93.

Munsell: core: 2.5YR 4/1 and 2.5YR 5/8; int.: 2.5YR 5/8; ext.: 10YR 4/5; deco.: 2.5YR 8/1.

Diam.: 19; H.: 1.4; L.: 10.2; T. min.: 0.3; max.: 0.7.

Casserole. Inwards over folded rim. Rounded lip, flaring outwards. Ledge at int. rim. Dome shaped body; deco.: white vertical lines on rim.

*References:* Uscatescu (1996), p. 344, fig. 74 grupo XVI no. 394; Canivet (1992), fig. 11, no. 10; Seigne (1982-1983), p. 73, no. 5; Lichtenberger, Raja, Sørensen (forthcoming), fig. 92.

Byzantine.

#### **Storage Vessels (AHS; AR)**

94.

J13-Ed-23-14

Fig. 94.

Body, fragmented.

Munsell: core: 2.5YR 4/1; slip: 7.5YR 8/3; deco.: 10R 4/6.

H.: 1.2; L.: 3.5; T.: max: 0.35; min.: 0.3.

Sherd with thick light coloured slip and painted red deco. int.: two curving lines; According to Smith: "red-on-cream"; Watson: "Ware P"; Gutfeld: "Red Painted Ware"; Walmsley: "Ware 8".

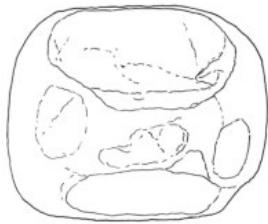

FRONT VIEW

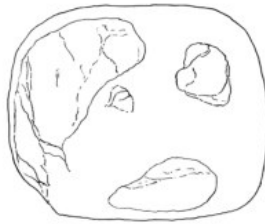

BACK VIEW

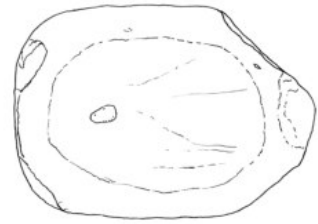

LEFT VIEW

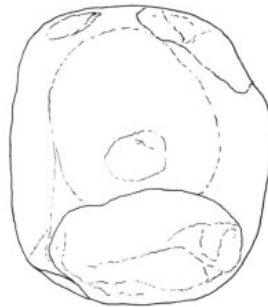

TOP VIEW

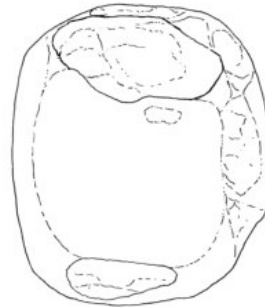

BOTTOM VIEW

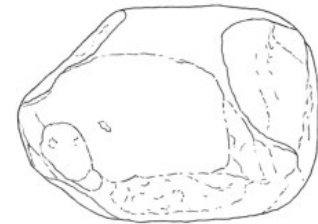

RIGHT VIEW

**140**

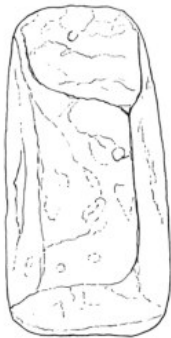

FRONT VIEW



BACK VIEW



LEFT VIEW

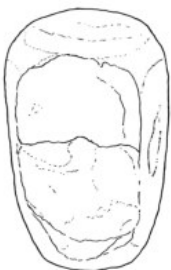

TOP VIEW



BOTTOM VIEW



RIGHT VIEW

**141**



*References:* Smith (1973), p. 234, pl. 30 no. 492, pl. 45 no. 488; jar exhibited in the Umayyad show case at the Jerash Museum; Bujard and Joguín (2001), p. 140, fig. 1: 1-6; Watson (1992), p. 244; Gutfeld (2010), p. 110; Walmsley (1995), p. 661.

Umayyad – Abbasid.

**Amphorai/Amphoriskoi (AR)**

*Rim*

95.

J13-Fh-29-11

Fig. 95.

Rim and shoulder, fragmented.

Munsell: core: 2.5YR 5/6; int.: 5YR 5/3; ext.: 5YR 4/2.

Diam. rim: 12; H.: 6.7; L.: 5.9; T. max.: 0.5; T. min.: 0.2.

Outwards folded rim; body horizontally ribbed; moderately elevating shoulder with slightly convex band.

*References:* Brown (1979), p. 23, fig. 1, 17; Uscatescu (1996), p. 259, no. 515 (p. 353, fig. 83.515; group XXXIV).

Byzantine.

*Base*

96.

J13-Gf-29-4

Fig. 96.

Base, fragmented.

Munsell: core: 5YR 6/8; int./ext.: 5YR 7/4.

Diam. base: 2.94; H.: 9.4; L.: 4.9; T. max.: 2.9; T. min.: 0.8.

Oval and rounded flat base and lower part of an amphora; base slightly convex; body steeply rising.

*References:* Gandolfi et al. (2010), p. 36, p. 49, fig. 5, 5.

Byzantine (5<sup>th</sup> – 6<sup>th</sup> century AD).

*Handle*

97.

J13-Ha/Ha1-14-10

Fig. 97.

Handle, fragmented.

Munsell: core1: 10YR 6/1; core2: 2.5YR 6/6; int.: 2.5YR 6/6; ext.: 10YR 7/3.

H.: 3.5; L.: 8.2; W.: 2.8.

Upper part of a double-barreled handle of the Koan type; rather coarsely levigated with few inclusions and air pockets.

*References:* Berlin (1997), pl. 66; Tyers (1996, 2012), <http://potsherd.net/atlas/Ware/DR2-4>

Late Hellenistic – early Roman (1<sup>st</sup> century BC – 2<sup>nd</sup> century AD).

*Body*

98.

J13-Dab-13-76

Fig. 98.

Body, fragmented.

Munsell: core and surface: in between 2.5YR 5/6 and 2.5YR 5/8.

Diam. max.: 6.26; H.: 7.0; L.: 5.6; T. max.: 1.7; T. min.: 0.7.

Lower part of an amphora; medium levigated with filled with silver mica. Smith and Day: “Micaceous ware”, import.

*References:* Smith and Day (1989), p. 106, fig. 50.5.

Late Roman – Byzantine.

99.

J13-Dab-13-71

Fig. 99.

Body, fragmented.

Munsell: core: 2.5YR 5/8; int.: Gley 1/5N; ext.: 10YR 7/2; paint: White Page 10YR 2/9.

H.: 14.9; L.: 10.6; T.: max: 3.2; min.: 2.5.

Water jar/amphora?; thin walled ribbed ware, hard fired, with small stone grits. Combed decoration in a thin reserved band on the body. White paint covers the surface of the vessel.

Late Umayyad - Abbasid (?).

*Reddish/Red Brown Ware*

100.

J13-Dab-13-54

Rim, fragmented.

Fig. 100.

Munsell: core: 10R 5/8; int.: 10R 5/8; ext.: 10R 6/6.

Diam.: 7; H.: 5.32; L.: 8.35; T. min: 0.35; max: 0.55.

Amphora or jar with straight, short neck with rounded rim; globular body shape. Concave ledge at shoulder.

*References:* Kenkel (2012), taf. 41, no. Am 22.1a & Am 22.1b; Canivet (1992) fig. 1 no. 6.

Late Roman – Byzantine.

*Grey Ware*

101.

J13-Ed-23-13

Fig. 101.

Base, fragmented.

Munsell: core and surface: GLEY 1 7/N.

Diam. base: 6; H.: 5.5; L.: 9; T.: 0.5.

Hollow-based with moderately elevating body; ribbed surface.

*References:* Rasson and Seigne (1989), p. 142, no. 43 (p. 141, fig. 11,7); Smith (1981), p. 321, fig. 2, 12; Uscatescu (1996), p. 261, no. 599 (p. 362, fig. 599; group XXXVII).

Byzantine.

**Pithos (AR)**

*Rim*

102.

J13-Dab-13-53

Fig. 102.

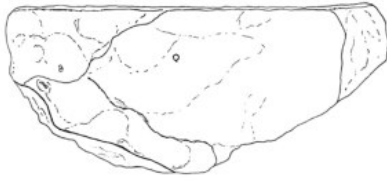

FRONT VIEW

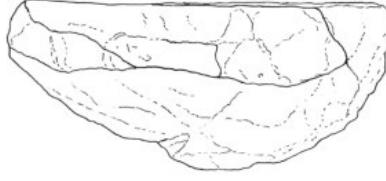

BACK VIEW

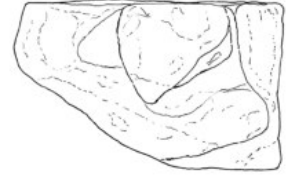

LEFT VIEW

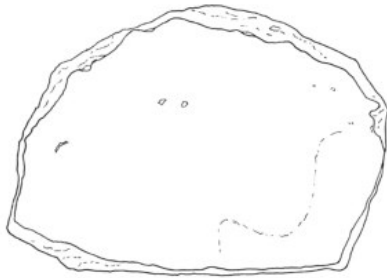

TOP VIEW

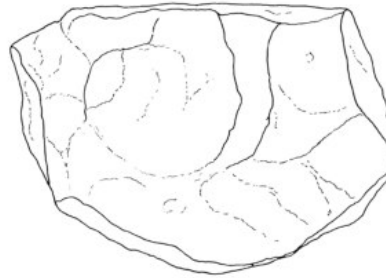

BOTTOM VIEW

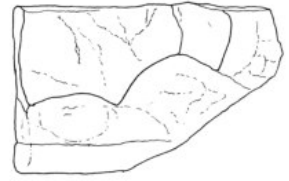

RIGHT VIEW

142

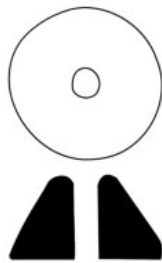

143

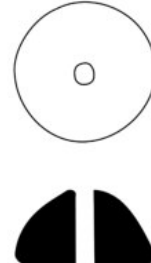

144

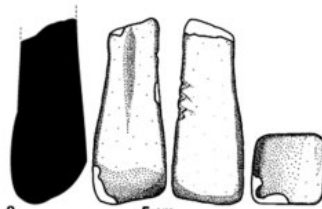

145



Rim and body, fragmented.

Munsell: core1: GLEY 1 5/1; core2: 2.5YR 4/8; int.: GLEY 1 5/1; ext.: 10YR 6/2.

Diam. rim: 28; H.: 11.2; L.: 16.1; T. max.: 2.6; T. min.: 0.3.

Pithos rim; sharply outwards bending rim; deco.: two combed horizontal wavy lines and single straps of combed lines in between. Magness: "Holemouth jar".

*References:* Najjar (1989), p. 316, no. 27 (p. 315, fig. 6, 27); Uscatescu (1996), p. 263, no. 651 (p. 367, fig. 97,651; group XLI); Magness (1993), p. 231-234.

Late Byzantine (Uscatescu); Abbasid (Najjar).

### **Basins (AR)**

#### *Rims*

103.

J13-Eac-13-6

Fig. 103.

Rim, fragmented.

Munsell: core: 2.5YR 6/1; int.: 2.5YR 6/1; ext.: 7.5YR 8/1.

Diam. rim: 54; H.: 6.5; L.: 6.1; W.: 1.7; T. max.: 1.2; T. min.: 0.5.

Basin; rim wheel-made, adjunctive body hand-made; below rim band of irregular impressions; very steep rim, on top almost straight.

*References:* Brown (1979), p. 23, fig. 1, 27; Jäggi *et al.* (1997), p. 320, no. 36 (p. 319, fig. 8,36); Uscatescu (1996), p. 260, no. 547 (p. 356, fig. 86,547; group XXXVI).

Late Byzantine.

104.

J13-Ec-27-24

Fig. 104.

Rim and body with attached handle.

Munsell: core1: 5YR 6/1; core2, int., ext.: 2.5YR 7/6.

Diam. rim: 40; H.: 11.8; W.: 1.4; T.: 0.6.

Basin; coarse ware storage vessel; rather steep body; band of impressed fingerprints separating body from rim; steep slightly inwards tending rounded rim; handle attached to the body.

*References:* Rast and Schaub (1974), p. 51, no. 296 (p. 50, fig. 11,296); Uscatescu (1996), p. 260, no. 549 (p. 357, fig. 87,549; group XXXVI).

Late Byzantine.

105.

J13-Ha/a1-13-10

Fig.105.

Rim, fragmented.

Munsell: core: 7.5YR 8/4; slip: White page: 2.5Y 2/9.5.

Diam.: 28; H.:1.7; L.: 2.5; T.: min.: 0.5, max.: 0.8.

Basin; rounded rim, of a cream coloured fabric, hard fired with brown and lime inclusions and covered in a thick whitish slip. Probably correspond to one of the cream wares occurring in the 8<sup>th</sup> century AD.

*References:* ware: Whitcomb (2008), p. 490.

Possibly Abbasid.

106.

J13-Fa-17-22-23

Rim and handle, fragmented.

Fig. 106.

Munsell: 7.5YR 6/1; int.: 7.5YR; ext.: 5YR 7/6.

Diam. (rim): 30; H.: 5.9, L.: 9.5; T. max.: 0.85; min.: 0.6.

Basin; medium fired and medium levigated clay. Horizontal handles pushed below the rim, three thumb impressions visible. Handle is not in a symmetrical angle to the rim.

#### *Orange Ware*

107.

J13-Ga-12-44

Rim, fragmented.

Fig. 107.

Munsell: core1: GLEY 8/R; core 2: 2.5YR 6/8; 2.5YR 6/8; 2.5YR 7/6.

Diam. (rim): 38; H.: 6.6, L.:20.2; W.: 3.1; T. (max.): 0.5.

Basin, hard fired and finely levigated clay with some air pockets included.

*References:* form: Clark (1986), fig. 20, no. 17; Uscatescu (1996), no. 372-374, p. 255; fig. 71-72; Pierobon (1986), p. 188, fig. 9, no. 8, 10.

Late Roman – Byzantine (3<sup>rd</sup> century – 7<sup>th</sup> century AD).

#### *Grey Ware*<sup>16</sup>

##### *Rims*

108.

J13-Eac-10-22

Fig. 108.

Rim, fragmented.

Diam. rim: 44; H.: 4.4; L.: 9; W.: 0.9; T. max.: 1; T. min.: 0.5.

Basin; steep body; band of stringed pointed oval shaped dots separating body from rim; outwards curving and rounded rim.

*References:* Uscatescu 1996, p. 255, no. 370 (p. 341, fig. 71,370; group XV).

Late Byzantine.

109.

J13-Ed-14-11+12

Fig. 109.

Rim and base, fragmented.

16. Munsell not indicated here. The colours correspond

to the description given of the ware in the 2012 report.



146a

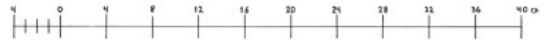

146b FRONT VIEW



146c

LEFT VIEW



RIGHT VIEW



FRONT VIEW

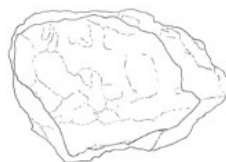

BACK VIEW



LEFT VIEW

147



TOP VIEW



BOTTOM VIEW



RIGHT VIEW

Diam. rim: 30; H. rim: 7.9; L. rim: 13.2; W. rim: 2.3; T. max. rim: 0.7; T min. rim: 0.5; H. base: 4.2; L. base: 6.1; T. max. base: 1; T. min. base: 0.7.

Basin; flat base; rather steep body; outwards bending rim; deco.: body decorated with irregular grooves incised by fingers; rim with finger impressions on the outside.

*References:* Rasson and Seigne (1989), p. 144, no. 57 (p. 145, fig. 13,2); deco. body: Uscatescu (1995), fig. 23, 77; Uscatescu (1996), p. 265, no. 728 (p. 375, fig. 105,728; group XXXVI).

Late Byzantine.

110.

J13-Ed-14-13

Fig. 110.

Rim, fragmented.

Diam. rim (inside): 61; H.: 8.6; L.: 12.5; W.: 2.8; T. max.: 1.2; T. min.: 0.5.

Basin; steep body and rim; slightly convex band below rim; deco.: combed wavy lines on body and on top of the rim.

*References:* Kehrberg (1989), p. 94, no. 7 (p. 91, fig. 7); Piccirillo and Russan (1976), p. 68, no. 11; Schaefer (1986), p. 430, fig. 10,1; Watson (1992), fig. 6, no. 43.

Late Byzantine – Umayyad.

111.

J13-Ed-18-5

Fig. 111.

Rim, body and base, almost intact.

Diam. rim: 42. Base: 24; H.: 19.5; T. base: 0.5, body: 0.7, rim: 2.

Basin; complete profile; flat base; rather steep body; slightly stepped and outwards bending rim.

*References:* Ball *et al.* (1986), p. 358, fig. 8; Rasson and Seigne (1989), p. 137, no. 27 (p. 133, fig. 7,7); Uscatescu (1996), p. 260, no. 557 (p. 357, fig. 87,557; group XXXVI).

Byzantine.

112.

J13-Fb-40-113

Fig. 112.

Rim and body with attached handle.

Diam. rim: 42; H.: 9.8; L.: 7.3; W.: 1.1; T. max.: 0.5; T. min.: 0.4.

Basin; rather steep body; S-shaped and rounded rim; handle attached to the body directly below rim.

*References:* Uscatescu (1996), p. 255, no. 361 (p. 340, fig. 70.361; group XV).

Late Byzantine.

113.

J13-Fi-34-3

Fig. 113.

Rim and body, fragmented.

Diam. rim: 42; H.: 8.6; L.: 9.9; W.: 3.4; T. max.: 1.9; T. min.: 0.9.

Basin; steep body; outwards bending rounded rim; deco.: horizontal pointed wavy incised lines on body; directly below rim band of impressed zigzag-shaped pattern.

*References:* Brizzi, Sepio and Baldoni (2010), p. 366, no. 3 (p. 366, fig. 12,3); Uscatescu (1996), p. 265, no. 748 (p. 377, fig. 107.748; group XXXVI).

Late Byzantine – Umayyad.

114.

J13-Dab-13-33

Fig. 114.

Rim, fragmented.

Diam. rim: 54; H.: 6.2; L.: 25.3; W.: 3.1; T.: 0.9.

Basin; steep body with slightly convex band below rim; outfolded rim with ten finger impressions on the ext.

*References:* Najjar (1989), p. 314, no. 13 (p. 313, fig. 5, 13); Schaefer (1986), p. 428, fig. 9, 12.

Umayyad.

#### **Unpainted handmade Coarse Ware - Ayyubid/ Mamluk**

*Rims*

115.

J13-Gf-33-14

Rim, fragmented.

Fig. 115.

Munsell: core: GLEY 2 4/10BG; int.: 5YR 7/8; ext.: 5YR 7/8.

Diam.: 30; H.: 4.7; L.: 6.1; T. min.: 0.8; max.: 1.2.

Bowl; convex sloping neck rounded out folded rim; surface smoothed.

*References:* Franken (1975) p. 135, fig. 64.

Late Ayyubid – Mamluk (late 12<sup>th</sup> – 14<sup>th</sup> century AD).

116.

J13-Ha1-16-15

Rim, fragmented.

Fig. 116.

Munsell: core: 10YR 4/1; int.: 10YR 7/4; ext.: 10YR 7/4.

Diam.: 32; H.: 7.3; L.: 9.7; T. min.: 1.4; max.: 1.9.

Jug; convex sloping neck; rounded, outward sloping rim.

*References:* Tholbecq (1997), p. 168 no. 38; Thuesen (1988), p. 277 no. 10.

Late Ayyubid – Mamluk (late 12<sup>th</sup> – 14<sup>th</sup> century AD).

117.

J13-Da-2-1, 2

Incense burner (bowl and lid), intact.

Fig. 117.

Munsell: int.: 5YR 6/6 and 5YR 7/3; ext.: 5YR 6/6 and 5YR 7/3.

Bowl: Diam. rim: 4.9; base: 2; H.: 2; L.: 4.9; T. min.: 0.3;



148a



148b



148c



149

max.: 1.

Lid: Diam. rim: 4.9; H.: 1.85; L.: 4.9; T. min.: 0.3; max.: 1.83.

Knob: H.: 1; W.: 2.5; T.: min.: 0.4; max.: 1.2.

Miniature incense burner. Bowl: ring base, outwards sloping body with rounded out folded rim. Lid: dome shaped; knob: flattened and rectangular, secondarily attached. Surface smoothed, but breakable. Very crooked, roughly made. Medium to coarse levigated. Sec. fired at ext.

*References:* McQuitty (1997), p. 226, fig. 21.

118.

J13-Da-2-3, 4, 5

Bowl, intact.

Fig. 118.

Munsell: core: 7.5YR 7/6; int.: 7.5YR 7/6; ext.: 7YR 6/8. Diam. rim: 7.4; base: 3.8; H.: 2.3; L.: 7.4; T. min.: 0.3; max.: 1.4.

Miniature bowl: flattened base, outwards sloping body with rounded, straightened rim. Surface smoothed, but breakable. Very crooked, roughly made. Medium levigated, air pockets.

*References:* McQuitty (1997), p. 226, fig. 21.

#### **Brick (AR)**

119.

J13-Ha/Ha1-13-37

Fig. 119.

Brick.

Munsell: core: 10YR 6/2; int./ext.: 10YR 6/2.

H.: 3; L.: 16.7; T. max.: 2.9; T. min.: 2.6.

Flat hand-made brick with incised mark 'K' on one surface; grooves from fingers on bottom.

*References:* Barnes *et al.* (2006), p. 307, fig. 17, 4.

Late Byzantine – early Islamic.

120.

J13-Ebd-19-24

Fig. 120.

Brick.

Munsell: core, int./ext.: 2.5YR 4/6.

H.: 3.3; L.: 17.7; T. max.: 2.6; T. min.: 2.5.

Flat hand-made rectangular brick with incised marks 'KE' on one surface.

#### **Tile (AR)**

121.

J13-Gf-30-3

Fig. 121.

Tegula.

Munsell: core, int./ext.: GLEY 1 7/N.

H.: 2.8; L.: 18.3; W. rim: 2; T. max.: 1.3; T. min.: 1.1.

Flat hand-made tile; outwards turned rounded rim.

*References:* Clark (1986), p. 317. p. 336, pl. 14.28.

Umayyad.

122.

J13-Ha/Ha1-13-39

Fig. 122.

Hollow tile.

Munsell: core: GLEY 6/10Y; int.: GLEY 5 N; ext.: 10YR 7/2.

H.: 11.1; L.: 27.5; T. max.: 5.3; T. min.: 1.3.

#### **Miscellanea**

##### **Unguentarium (PE)**

123.

J13-Ec-13-41

Rim/Spout, fragmented.

Fig. 123.

Munsell: core1: 2.5YR 7/3, core2: 2.5YR 7/1; int.: 2.5YR 4/2; ext.: GLEY2 5/5PB.

Diam. (max.): 2.9, (min.): 1.5; H.: 2.5; L.: 2.9; W.: 0.5; T. (max.): 0.80, (min.): 0.49.

Plain ware unguentarium, hand-made, hard-fired and rather finely levigated clay.

Late Roman.

##### *Terracotta (AR)*

124.

J13-Ga-12-22

Fig. 124.

Figurine, foot.

Munsell: core, int./ext.: 2.5YR 6/6

H.: 1.2; L.: 3.8; T. max.: 1.1; T. min.: 0.3.

Front part of the left foot of an anthropomorphic figurine; flat stand; space between toes slightly incised; big toe shows the nail.

Roman

125.

J13-Gb-9-7 and 15

Fig. 125.

Figurine, breasts.

Munsell: core, int./ext.: 2.5YR 6/6.

H.: 4.7; L.: 5.9; T. max.: 0.8; T. min.: 0.2.

Two joining pieces of a mould-made female draped figurine; two breasts showing the garment's folds running curved between the breasts.

*Roman*

126.

J13-Gb-12-58

Fig. 126.

Figurine, head, fragmented.

Munsell: core/int.: 2.5YR 6/6; ext.: 10R 7/6 and 5YR 8/3.

H.: 4.4; L.: 2.8; T. max.: 0.85; T. min.: 0.3.

Lower part of the face and neck of a mould-made figurine; fold surrounding the face.



150



151



FRONT VIEW

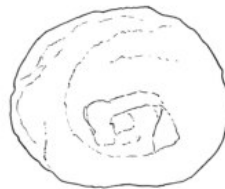

BACK VIEW

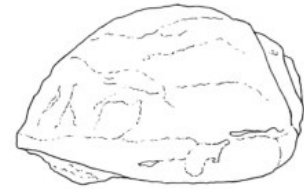

LEFT VIEW

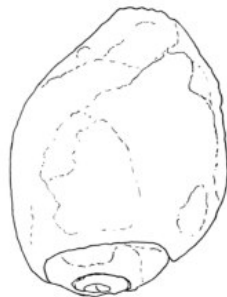

TOP VIEW



BOTTOM VIEW

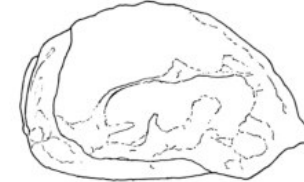

RIGHT VIEW

152



Roman

127.

J13-Gd-28-17

Fig. 127.

Horse-rider figurine, leg of rider and torso of horse, fragmented.

Munsell: core, int./ext.: 2.5YR 7/6.

H.: 4.9; L.: 4.8; W.: 1.8; T. max.: 1.5; T. min.: 0.12.

Leg of a rider turning towards the right, with bracelet around the ankle; part of the saddle and body of horse.

Roman

#### **Mould (AR)**

128.

J13-Fi-53-17

Fig. 128.

Mould of a mask.

Munsell: core: GLEY 1 5/N; int.: GLEY 1 5/N; ext.: 7.5YR 6/1 and 5YR 3/1.

H.: 7.1; L.: 5.5; W.: 1.8; T. max.: 0.9; T. min.: 0.3.

Left half of a rather flat mould of a chubby-cheeked (extended chins) male face showing chin, slightly opened mouth, part of the nose, one eye and brow and schematic strands of hair; traces of secondary firing on the exterior.

Roman – late Roman.

#### **Bone utilities (SKr)**

129.

J13-Dab-7-4

Worked bone spindle, almost intact.

Fig. 129.

Diam. (min): 0.4; Diam. (max): 0.6; H.: 3.6.

Worked bone; oblong, rounded shaft; cone-shaped top with central depression.

*References:* Clark *et al.* (1986), pl. XXVI, 1; Lichtenberger, Raja and Sørensen (forthcoming), no. 151.

130.

J13-Ec-27-51

Worked bone spindle, almost intact.

Fig. 130.

Diam. (min): 0.4; Diam. (max): 1.1; H.: 9.5.

Worked bone; oblong, rounded shaft with curving sides; rounded, oval top with a rounded projection; straight ridges around the shaft; depression at the base.

*References:* Riis (1969), fig. 44, nos. 3; Clark *et al.* (1986), pl. XXVI, 1, pl. XXVII, 1; Riis and Buhl (1990), fig. 99, no. 810; Findlater *et al.* (1998), fig. 8, no. 99 (similar).

131.

J13-Ha/Ha1-16-1

Shaft and proximal end of a bone, fragmented.

Fig. 131.

Worked metatarsal from a horse; saw marks; either remains from butchering, or from ornamental craft work.

#### **Metal objects (PE)**

132.

J13-Dab-19-14+15

Iron key.

Fig. 132.

L.: 2.7; H.: 9.6; H.:2: 1.3; T. (max.): 1.8; (min.): 1.4.

Very corroded iron key. Found in a fire place in situ. Glued together (modern conservation 2013), the key has a long shape, with a ring in the middle and four bumps on the key bit.

*References:* Shape: Crowfoot (1957), p. 446, no. 6, fig. 105; Goldmann (1950), IX, no. 73; bid shape: Waldbaum (1983), no. 392-394, pl. 25; bronze example in: Kol-Yaakov (2000), p. 494, no. 90; pl. IX, no. 3.

Roman – Byzantine.

133.

J13-Da-22-1

Iron blade.

Fig. 133.

L.: 30.8; W.: 7.0; diam. (first attachment): 1.2.

Very corroded iron blade of a short knife. Remains of the attachments to hold the handle are still visible. Conservation revealed: the iron oxides fossilized the scabbard in oxidation process, meaning, the rust on the surfaces shapes the scabbard, which seems to have been consisting of leather with yarn embroideries for decoration.

*References:* form: Fisher (2000), fig. 5.1, no. 9.

Possibly Roman – Byzantine.

134.

J13-Fe-21-9

Copper alloy jewellery

Fig. 134.

Ball: H.: 0.9; L.: 0.8. chain L.: 1.6; total L.: 2.6.

Piece of jewelry, in the shape of a small ball hanging on a chain. Well preserved.

135.

J13-Ha/a1-13-4

Unidentifiable bronze tool or clasp.

Fig. 135.

H.: 10.5; T.: ca. 0.3; W.: 0.6.

Corroded and bended object: A clasp or a bronze tool (?).

*References:* Bears slight resemblance to socket keys (Gaitsch (2005), S2 15-16, p. 204; pl. 4).

136.

J13- Ga-21-11

Gold wire.

Fig. 136.

L.: c. 2 (twisted); T. (max.): 0.1.

The small and thin wire is twisted. It was cleaned from the corrosion of an iron-object from the same context. The

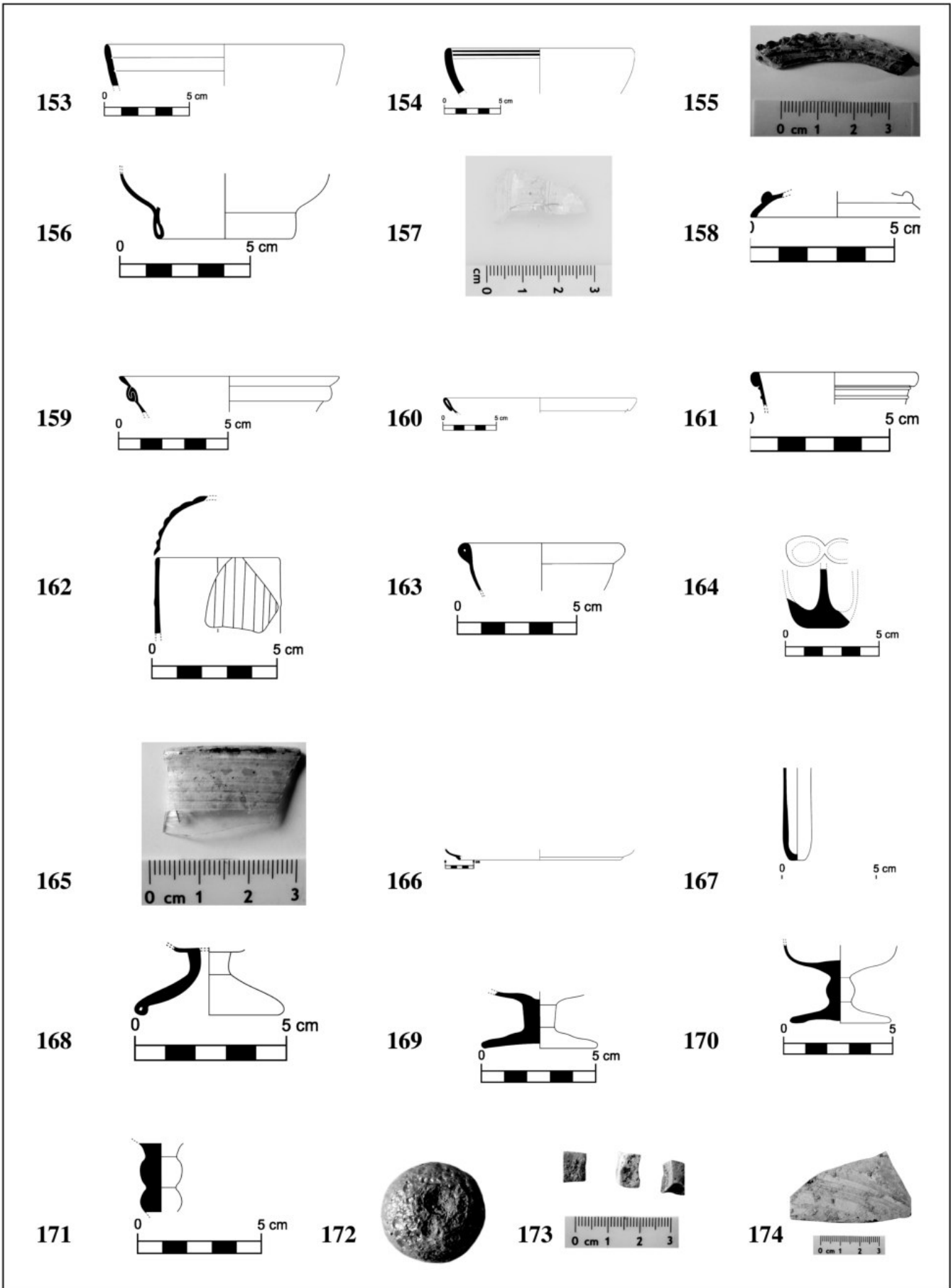

ends of the string are twisted two and three times around the string. Jewellery fragment.

#### **Stone Utensils (AMB)**

##### *Vessel*

137.

J13-Ha/a1-13-48

Base fragment of limestone mug.

Fig. 137.

Diam. base: 12; H.: 9; L.: 1.5; T.: 0.7 – 1.

Flat base mug; vertical cut marks.

*References:* Deines (1993); Geva (2010), pl. 5.4.

Early Roman (1<sup>st</sup> cent. BC – 1<sup>st</sup> cent. AD).

##### *Mortars*

138.

J13-Hc-3-1

Basalt mortar, fragmented.

Fig. 138.

H.: 10.8; L.: 18.4; T.: 5.1; W. base: 6.8.

Almost 1/3 of a well preserved mortar, one base completely preserved; slightly covered in lime; the stone is dark grey/black.

*References:* Clark *et al.* (1986), fig. 24; Riis *et al.* (1990), fig. 77, 78; Thuesen (1988), Pl. 51.12

139.

J13-Da-10-32

Basalt bowl, fragmented.

Fig. 139.

Diam.: c. 22; H.: 9.5; L.: 18.4; T.: 1.9–5.8.

Rim of a basalt mortar; rounded foot; smoothed int. and ext. surface; the stone is black/grey.

*References:* Clark *et al.* (1986), fig. 24; Riis *et al.* (1990), fig. 78.

##### *Grinders*

140.

J13-Dab-13-17

Limestone object, possible grinder, fragmented.

Fig. 140.

H.: 8.3; L.: 9.6.

Rounded to square; smoothed surfaces on all four sides; the stone is white/brown.

*References:* McNicoll *et al.* (1992), plate 73 no. 2.

141.

J13-Ed-23-1

Possible grinder, fragmented.

Fig. 141.

H.: 9.5; L.: 7.5; T.: 3.7–4.8.

Smoothed surfaces; trapezoidal shape with heavily rounded corners; one hollow on both sides; the stone is black/grey.

*References:* McNicoll *et al.* (1992), plate 73 no. 2.

142.

J13-Dab-17-7

Basalt grinding stone.

Fig. 142.

H.: 12; L.: 26.5; T.: 19.

Flattened on one side, rounded on the other; the stone is greyish.

*References:* McNicoll *et al.* (1992), plate 72 no. 4, plate 73 nos. 1 and 6.

##### *Spindle whorls (SKr)*

143.

J13-Dab-7-1

Fig. 143.

Diam.: 3; H.: 1.6.

Intact cone-shaped spindle whorl with central hole; flat top and base; sandstone, light brown/white.

*References:* Riis (1969), fig. 39, nos. 8; McNicoll *et al.* (1982), plate 132, no. 7; Riis and Buhl (1990), fig. 97, no. 752-765; Lichtenberger, Raja and Sørensen (forthcoming), no. 158 and 159.

144.

J13-Db-19-17

Fig. 144.

Diam.: 2.8; H.: 1.5.

Intact cone-shaped spindle whorl with central hole; flat top and base; Steatite, black with white streaks.

*References:* Riis (1969), fig. 39, nos. 8; McNicoll *et al.* (1982), plate 132, no. 7; Riis and Buhl (1990), fig. 97, no. 752-765; Lichtenberger, Raja and Sørensen (2013, forthcoming), no. 158 and 159.

##### *Loomweight (AMB)*

145.

J13-Dab-13-61

Loomweight.

Fig. 145.

H.: 6.7; T.: 1.8–2.6.

Smoothed surfaces; deep groove on one side; three grooves in one corner and two in another; the stone is brown/grey.

*References:* McNicoll *et al.* (1992), plate 79.b.

##### **Sculpture (AL; RR)**

146.

J13-Da-10-2x

Torso of Artemis Rospigliosi.

Figs.: 146a-c.

Whitish marble, crystalline.

Diam.: 24; H.: 30 (max), H. of drapery: 24; W.: 30; D.: 24. Female torso almost life-size of an Artemis Rospigliosi type (LIMC, Artemis-Diana, p. 808pp, no. 35a-i). The sculpture was re-used as a building block roughly dressed

175a



175b



176a



176b

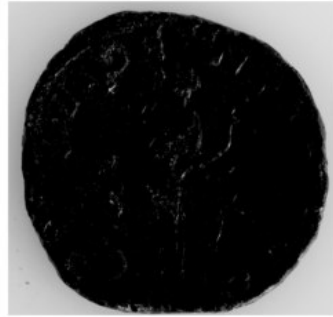

177a

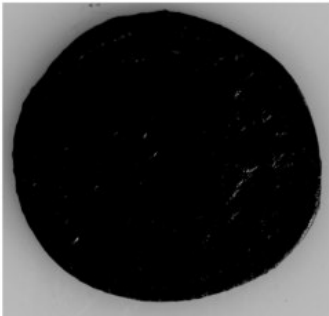

177b

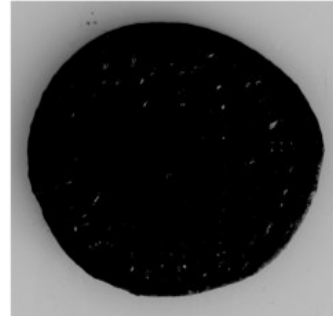

178a

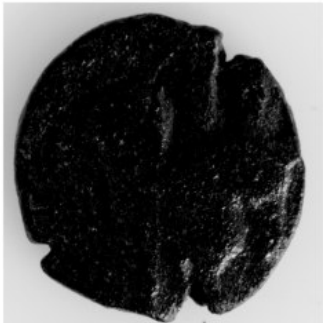

178b



179a

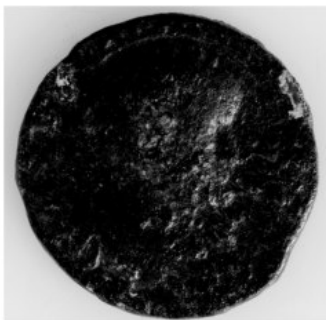

179b



180



in the 'Ionic Building'. It is preserved from below the neck until above the navel. The surface of the front is damaged and the backside is cut vertically to fit secondary use as a building block. The torso is wearing a chiton with a belt knotted with a badly damaged Heracles-knot right under the breasts. On the left side a fold of thick drapery hangs over the belt. Between the breasts a rich asymmetrical but schematized drapery falls towards the knot of the belt. The sculpture is carved in low relief; the folds are highly schematized. The product most likely stems from a local workshop of the second or third century AD.

The Artemis Rospigliosi, going back to a 2<sup>nd</sup> century BC type, was a prominent Artemis type in this part of the Roman Near East. Further examples are known from Caesarea Philippi, Gerasa and probably also Pella.

*References:* Friedland (2012), 110-113 no. 15 figs. 50-51; Weber (2002), p. 486, no. C3, taf. 121E; Fischer (1938), p. 269, taf. 54; Weber (2002), p. 483, no. B1, taf. 118A-C; LIMC, Artemis-Diana, p. 808, no. 35a-i.

Roman (2<sup>nd</sup> or 3<sup>rd</sup> century AD) after Hellenistic original.

#### **Architecture (AMB)**

147.

J13-Dbd-8-1

Ionic capital, fragmented.

Fig. 147.

H.: 17.1; L.: 24.5; W.: 9.

Limestone.

Fragment of Ionic capital decorated with egg-and-dart and bead-and-reels; appears partly blackened by fire.

*References:* Kraeling (1938), pl. XLVI.b; Lichtenberger, Raja and Sørensen (forthcoming), cat. no. 166, but with beads in the bead-and-reel ornamentation more closely set, as illustrated in Nassar (2004), Pl. 29, 2.

Roman.

#### **Plaster – Wall paintings (AHS)**

148.

J13-Da-10-31; Dc-10-16; Db-10-27, Dcd-10-5, Dc-10-16, Da-10-9 – most probably from the same decoration as J13-Db-29-8

Painted plaster, fragmented.

Figs. 148a-c.

Colours: red, yellow, black, blue, and pink.

Painted and unpainted plaster fragments. The decoration seems to have mainly consisted of parallel bands of colours of varying width. The paintings have been constructed on a base of coarse plaster covered by a very finely levigated and thinner layer of plaster. On some of the fragments string impressions used as guidelines for the paint are preserved. The painting technique has not been analysed but the thick layers of paint give the impression of al secco painting.

*References:* Bloch (2011), p. 120-121, Taf. 58-61; Cruikshank Dodd (2004); Ettinghausen (1962); Schlumberger (1986).

Mamluk.

149.

J13-Db-29-8 – most probably from the same decoration as J13-Da-10-31; Dc-10-16; Db-10-27, Dcd-10-5, Dc-10-16, Da-10-9

Fig. 149.

Colours: red, yellow, black, and blue.

Painted and unpainted plaster fragments. The decoration seems to have mainly consisted of parallel bands of colours of varying width. The paintings have been constructed on a base of coarse plaster covered by a very finely levigated and thinner layer of plaster. The painting technique has not been analysed but the thick layers of paint give the impression of al secco painting.

*References:* Bloch (2011), p. 120-121, Taf. 58-61; Cruikshank Dodd (2004); Ettinghausen (1962); Schlumberger (1986).

Mamluk.

#### **Wasters and Crucibles (AHS)**

150.

J13-Fh-29-3

Fig. 150.

Wasters.

H.: 4.8; L.: 10.5; W.: 5.9.

Wasters from local pottery production.

151.

J13-Fd-40-5

Fig. 151.

Crucible, rim, fragmented.

Diam.: 44; H.: 6.7; L.: 6.2.

Crucible from local production. Ceramic vessel on ext. clay packing, int. remains of the melted material heated in the vessel.

#### **Fossil (AHS)**

152.

J13-Db-27-1

Fig. 152.

H.: 10.3; D.: 16.1; W.: 12.3.

Large Steinkern (stone cast) of a gastropod, built into a wall.

Most likely stems from the Paratethys ocean.

Tertiary

#### **Glass (HS)**

153.

J13-Ec-13-44

Rim fragment of a conical grooved bowl with two horizontal grooves on the interior.

Fig. 153.

Amber, translucent; white weathering and iridescence.

Diam. (rim): 14; H.: 2.45; T.: min: 0.3, max: 0.4.

*References:* Grose (2012), p. 37, no. G 107, fig. 12, pl. 8.

181a

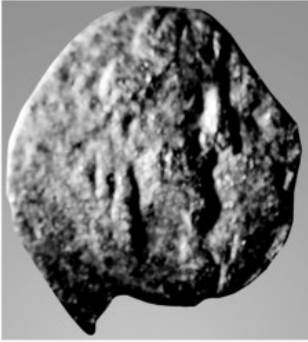

181b



182a



182b



183a

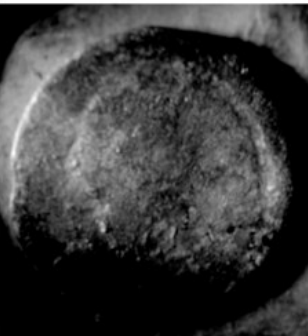

183b

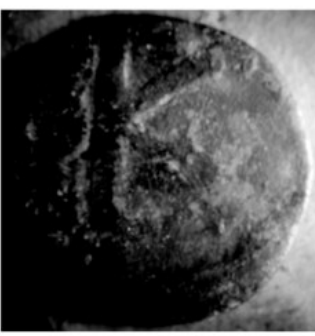

184a

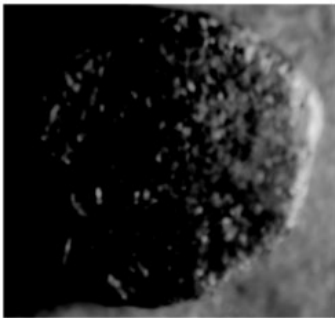

184b



185a



185b



Hellenistic (mid-2<sup>nd</sup> – mid-1<sup>st</sup> century BC).

154.

J13-Ha1-13-50

Rim fragment of a hemispherical grooved bowl with two horizontal grooves on the interior.

Fig. 154.

Purple, translucent; weathering and iridescence.

Diam. (rim): 16; H.: 4; T.: min: 0.57, max: 0.66.

*References:* Dussart (1998), p. 51, group AII.11, pl. 1, 8 (late 3<sup>rd</sup> century BC); Jennings (2004/2005), p. 34, no. 2.5.6, fig. 2.5.6 (60–50 BC); Grose (2012), p. 42, no. G 162, fig. 16, pl. 10; Antonaras (2012), p. 55, no. 18 (c. 150 – 50 BC).

Hellenistic (mid-2<sup>nd</sup> – mid-1<sup>st</sup> century BC).

155.

J13-Gb-7-18

Rim fragment of a small bowl with an applied strip-handle, consisting of a thick crimped trail.

Fig. 155.

Light bluish green, transparent; dark weathering and iridescence.

Diam. (rim) 11.

*References:* Meyer (1988), p. 185, fig. 5 G. H; Weinberg (1988), p. 55, no. 118–121, fig. 4-16, pl. 4-7; Arveiller-Dulong – Nenna (2005), p. 190, no. 522. 523 (late 1<sup>st</sup> – 2<sup>nd</sup> century AD); Keller (2006), p. 210, type VII.19b, no. 692, pl. 11f (early 2<sup>nd</sup> century AD); Jennings (2004/2005), p. 73–74, no. 4.5.2, fig. 4.5.2 (4<sup>th</sup> century AD).

Context date: early Byzantine/Umayyad.

Mid-/late Roman (2<sup>nd</sup> – 4<sup>th</sup> century AD).

156.

J13-Gb-12-49

Foot fragment of a deep bowl with a high folded base-ring.

Fig. 156.

Yellowish green, translucent; dark weathering and iridescence.

Diam. (base): 5; H.: 2.5; T. rim: 0.38, body: min: 0.11, max: 0.2.

*References:* Hayes (1975), p. 120, no. 470, fig. 12 (late 3<sup>rd</sup> – 4<sup>th</sup> century AD); p. 158, no. 652, fig. 21 (about 3<sup>rd</sup> century AD); Jennings (2004/2005), p. 190, no. 8.3.6, fig. 8.3.6; Weinberg and Stern (2009), p. 125, no. 213, fig. 15, pl. 20 (mid-3<sup>rd</sup> century AD).

Mid-/late Roman (3<sup>rd</sup> – 4<sup>th</sup> century AD).

157.

J13-Ga-12-18

Wall fragment of a hemispherical bowl, decorated with two sections of engraved lines and long oval facets between them.

Fig. 157.

Colourless, opaque; white weathering and iridescence.

Diam. not definable. H.: 2; T.: min: 0.18, max: 0.30.

*References:* Shepherd (1999), p. 313, no. 12, fig. 11.2 (late 2<sup>nd</sup> or 3<sup>rd</sup> century CE); Weinberg and Stern (2009), p. 123, no. 200, fig. 13, pl. 19 (probably mid-3<sup>rd</sup> century AD); Kakhidze and Shalikadze (2009), p. 77, no. 88, fig. 29 (3<sup>rd</sup> – 4<sup>th</sup> century AD).

Mid-/late Roman (3<sup>rd</sup> – 4<sup>th</sup> century AD).

158.

J13-Hc-3-3

Rim fragment of a bottle or jug, decorated with a thick horizontal trail below the rim.

Fig. 158.

Pale greenish blue, translucent; dark weathering and iridescence.

Diam. (base) 6; H.: 0.9; T.: min: 0.15, max: 0.38.

*References:* Weinberg (1988), p. 65, no. 217-228, fig. 4-28 (4<sup>th</sup> century AD); Jennings (2004/2005), p. 113–114, no. 5.27.1–10, fig. 5.27 (second half 4<sup>th</sup> – 5<sup>th</sup> century AD); Keller (2006), p. 228, type VII.57b, no. 1855, pl. 20k (4<sup>th</sup> – early 5<sup>th</sup> century AD); Schwarzer (2009a), p. 70, no. 12, pl. 1 (3<sup>rd</sup> – 4<sup>th</sup> century AD); Antonaras (2012), p. 168 no. 240 (3<sup>rd</sup> – 4<sup>th</sup> century AD).

Mid-Roman – early Byzantine (3<sup>rd</sup> – 5<sup>th</sup> century AD).

159.

J13-Gb-9-9

Rim fragment of a bowl; below the rim a horizontal rib surrounds the body, formed by a double fold in the glass wall.

Fig. 159.

Pale green; dark weathering and iridescence.

Diam. (rim) 10; H.: 1.66; T.: min: 0.1, max: 0.5.

*References:* Hayes (1975), p. 120, no. 472, fig. 13, pl. 30 (4<sup>th</sup> century AD); Weinberg (1988), p. 53–54, no. 108–1, fig. 4-15, pl. 4-7 (second half 4<sup>th</sup> century AD); Whitehouse (1997), p. 79, no. 103 (4<sup>th</sup> century AD).

Late Roman (4<sup>th</sup> century AD).

160.

J13-Gb-3-21

Rim fragment of a bowl with a broad outfolded rim and an in-curving wall.

Fig. 160.

Pale green, transparent.

Diam. (rim) 18; H.: 1.42; T.: min: 0.12, max: 0.49.

*References:* Weinberg (1988), p. 41–44, no. 12–36, fig. 4-3; Whitehouse (1997), p. 70, no. 81 (3<sup>rd</sup> – 4<sup>th</sup> century AD); Pollak (2006), p. 155–158, no. 9–18, fig. 127; Antonaras (2012), p. 106, no. 130 (4<sup>th</sup> century AD).

Late Roman (4<sup>th</sup> century AD).

161.

J13-Dab-13-42

Rim fragment of a bottle or jug, decorated with a thick trail on the lip and a thinner spiral trail below the lip around the neck; both trails are of the same colour as the body.

Fig. 161.

Pale greenish blue, translucent; white weathering.

Diam. (rim) 6; H.: 1.5; T. rim: 0.36, body: min: 0.1, max: 0.16.

*References:* Oliver (1980), p. 101, no. 159 (4<sup>th</sup> century AD); Atik (2009), p. 3, fig. 41 (4<sup>th</sup> – 7<sup>th</sup> century AD).

Late Roman – early Byzantine (4<sup>th</sup> – 5<sup>th</sup> century AD).

162.

J13-Eac-10-11

Body sherd from a mold-blown flask or jug with a vertical ribbed fluting pattern.

Fig. 162.

Pale greenish blue, transparent.

Diam.: 5; H.: 3; T.: min: 0.15, max: 0.22.

*References:* von Saldern (1974), p. 79, nos. 71 (jug). 72 (flask) (3<sup>rd</sup> – 4<sup>th</sup> century AD); Hayes (1975), p. 113, no. 428, pl. 27 (first half [?] 4<sup>th</sup> century AD); Oliver (1980), p. 125, no. 221; 126, no. 222 (5<sup>th</sup> century AD [?]); Stern (2001), p. 233, no. 119 (probably second half 4<sup>th</sup> century AD); Arveiller-Dulong and Nenna (2005), p. 427, no. 1193, pl. 108 (second half 4<sup>th</sup> century AD); Antonaras (2012), p. 98, no. 117 (4<sup>th</sup> century AD).

Late Roman – early Byzantine (4<sup>th</sup> – 5<sup>th</sup> century AD).

163.

J13-Ed-14-8 + J13-Ed-18-75

Four (three + one) rim fragments (belonging together but not joining) probably from a conical goblet.

Fig. 163.

Pale olive green, translucent; white weathering and iridescence, sintered.

Diam. (rim) 7; H.: 2; T.: rim: 0.56, body: 0.11.

*References:* Hayes (1975), p. 104, no. 379, fig. 11 (4<sup>th</sup> century AD); Meyer (1988), p. 189, fig. 5 T; Stern (2001), p. 310, no. 173 (probably mid-6<sup>th</sup> – 7<sup>th</sup> century AD); Lightfoot (2007), p. 93, no. 212 (4<sup>th</sup> century AD).

Late Roman – early Byzantine (4<sup>th</sup> – early 7<sup>th</sup> century AD).

164.

J13-Fd-15-19

Base of a double kohl tube.

Fig. 164.

Yellowish green, translucent; white weathering, pontil mark visible.

Diam.: max : 4 ; H. (preserv.) 3.1 ; T. : min : 0.34, max : 0.95

*References:* Hayes (1975), p. 101, no. 359, pl. 28 (4<sup>th</sup> century AD); Meyer (1988), p. 194, fig. 7. U; Dussart (1998), p. 173, pl. 57, 16, group BXIII.211 (late 6<sup>th</sup> century AD); Whitehouse (2001), p. 195, no. 747 (4<sup>th</sup> –

5<sup>th</sup> century AD); Israeli (2003), p. 231, no. 291 (4<sup>th</sup> – 6<sup>th</sup> century AD); Arveiller-Dulong and Nenna (2005), p. 484, no. 1322 (5<sup>th</sup> century AD); Antonaras (2012), p. 265, no. 434 (4<sup>th</sup> century AD).

Late Roman – early Byzantine (4<sup>th</sup> – early 7<sup>th</sup> century AD).

165.

J13-Fd-40-1

Rim fragment of a conical cup, decorated with a blue spiral trail on rim and body. Measurements not available.

Fig. 165.

Colourless, transparent; white weathering.

*References:* Shepherd (1999), p. 327, no. 138, fig. 11.7 (2<sup>nd</sup> – 3<sup>rd</sup> century AD); Jennings (2004/2005), p. 159, no. 7.2.20, fig. 7.2.20 (first half 6<sup>th</sup> century AD); Keller (2006), p. 219, type VII.33b, no. 1209, pl. 161 (late 6<sup>th</sup> century AD); Pollak (2006), p. 174, no. 109, fig. 137; Adam-Veleni (2010), p. 350, no. 376 (5<sup>th</sup> – 6<sup>th</sup> century AD).

Late Roman – early Byzantine (mid 4<sup>th</sup> – early 7<sup>th</sup> century AD).

166.

J13-Dab-17-11

Foot fragment with folded base-ring, unusually turned inwards; probably from a large plate.

Fig. 166.

Yellowish green, translucent.

Diam. (foot) 28; H.: 1.8; T.: base: 0.57, body: min: 0.12, max: 0.38.

*References:* Only two comparable pieces are known, both from Gerasa itself: Meyer (1988), p. 194, fig. 7. I; 198, fig. 8. P.

Early Byzantine (5<sup>th</sup>/6<sup>th</sup> century AD).

167.

J13-Fd-40-3

Stemmed hollow foot of a polycandelon lamp.

Fig. 167 .

Light yellow-green, translucent; white weathering, pontil mark visible.

Diam. base: 1; H.: 5.3; T.: min: 0.16, max: 0.39.

*References:* von Saldern (1980), p. 51, no. 280, pl. 23 (Early Byzantine); Oliver (1980), p. 117, no. 202 (5<sup>th</sup> or 6<sup>th</sup> century AD); Whitehouse (1997), p. 196, no. 343 (c. 5<sup>th</sup> century AD); Jennings (2004/2005), p. 142, no. 6.16.2, fig. 6.16.2 (first half 6<sup>th</sup> century AD); Czurdar-Ruth (2007), p. 182, no. 811, pl. 21.

Early Byzantine (5<sup>th</sup> – 6<sup>th</sup> century AD).

168.

J13-Ed-18-76

Foot fragment of a goblet with a hollow stem and a conical foot with a tubular folded edge.



Fig. 168.

Pale greenish blue, transparent; white weathering.  
Diam. (foot) 5; H.: 2.24; T. base: min: 0.3, max: 0.46, body: 0.12.

*References:* Meyer (1988), p. 199, fig. 8. bb; Whitehouse (1997), p. 105, no. 156 (4<sup>th</sup> century AD or later); Dussart (1998), p. 116, pl. 27, 38, group BIX.1 (Byzantine); Schwarzer (2009a), p. 72, no. 40, pl. 3; Çakmakçi (2009), p. 62, tab. 2, type A1b.

Early Byzantine (5<sup>th</sup> – early 7<sup>th</sup> century AD).

169.

J13-Fa-9-5

Foot fragment of a goblet with a solid foot and a solid short stem.

Fig. 169.

Yellowish green, translucent; pontil mark visible.

Diam. (foot) 5.2; H.: 2.5; T. stem: min: 1.31, max: 1.5; base: min: 0.31, max: 0.52; body: min: 0.16, max: 0.42.

*References:* Meyer (1988), p. 206, fig. 10. Y; Dussart (1998), p. 121, pl. 29, 1, group BIX.2 (first half 8<sup>th</sup> century AD); Hadad (2005), p. 130, no. 402, pl. 21 (Umayyad); Çakmakçi (2009), p. 63, tab. 5, type B1b.

Early Byzantine – early Umayyad (5<sup>th</sup> – second half 7<sup>th</sup> century AD).

170.

J13-Db-13-1X

Fragment of a goblet with a solid foot and a solid stem with one knob.

Fig. 170.

Pale greenish blue, translucent; white weathering, pontil mark visible.

Diam. (foot) 4.6; H.: 3.57; T.: stem: min: 0.86, max: 1.32, body: min: 0.12, max: 0.65.

*References:* Jennings (2004/2005), p. 130, no. 6.3.16, fig. 6.3.16 (late 6<sup>th</sup>/early 7<sup>th</sup> century AD); Hadad (2005), p. 130, no. 409, pl. 21 (Umayyad); Schwarzer (2009b), p. 92, no. 34, pl. 2; Çakmakçi (2009), p. 64, tab. 7, type B1d. Early Byzantine – early Umayyad (5<sup>th</sup> – second half 7<sup>th</sup> century AD).

171.

J13-Fa-9-1

Lower part of a solid stemmed lamp, decorated with two knobs.

Fig. 171.

Greenish blue, translucent; white weathering, pontil mark visible.

H. max. 2.8; diam. (knobs): 1.6; stem: min.: 1.18, max.: 1.78.

*References:* Baur (1938), p. 519–521, no. 1–3, fig. 17 (5<sup>th</sup> or 6<sup>th</sup> century AD); Meyer (1988), p. 212–213, fig. 13. A. B; Dussart (1998), p. 88, pl. 16, 13–16, group BVI.23 (early 4<sup>th</sup> – 12<sup>th</sup> century AD); Jennings (2004/2005), p.

147, no. 6.20.6, fig. 6.20.6 (late 6<sup>th</sup> century AD); Hadad (2005), p. 132, no. 426, pl. 22 (Umayyad).

Early Byzantine (late 6<sup>th</sup> century AD) – Umayyad/Abbasid (8<sup>th</sup>/9<sup>th</sup> century AD).

172.

J13-Fc-15-12

Small pearl bead.

Fig. 172.

Blue (?); yellowish weathering.

Diam. (max.) 0.5.

*References:* Spaer (2001), p. 64; Schwarzer (2009a), p. 75, no. 71, pl. 4.

Hellenistic – early Islamic.

173.

J13-Fh-29-2

Three tesserae.

Fig. 173.

Pale blue, translucent.

Dimensions c. 0.8 x 0.9 x 0.6.

*References:* Schwarzer (2009a), p. 75–76, no. 83, pl. 4; James (2010).

Mid-Roman – early Islamic.

174.

J13-Dab-13-39

Fragment of a casted window pane.

Fig. 174.

Yellowish green, translucent; streaks, white weathering.

Dimensions: 6.7 x 5.0; T. c. 0.5 cm.

*References:* Hadad (2005), p. 136, no. 473, pl. 24 (Umayyad); Pollak (2006), p. 187–188, no. 192, fig. 144; Schwarzer (2009a), p. 76, no. 88, pl. 4.

Late Roman – early Islamic.

## Coins

175.

J13-Da-18-2X

Fig. 175a-b.

AE; Follis.

Constantinople, Iustinianus I.

Wt: 16.02; diam. min: 2.880; diam. max: 3.194; 6h.

Obv.: [DN IVST]INI-ANVS [PP] A[VG]; draped and cuirassed bust of Iustinianus I. facing right, diademed.

Rev.: M – A – CON; large letter M with A for the officina below, CON below baseline.

*References:* Bellinger (1966), p. 78, no. 28a.1–28a.3; Morrisson (1970), p. 75, no. 4/Cp/AE/05; Wroth (1966), p. 29, no. 28.

AD 527–538.

176.

J13-Db-19-10

Fig. 176a-b.

AE, Sestertius.

Wt: 19.50; diam. min: 2.836; diam. max. 2.961; 12h.

Maximinus Thrax, Rome.

Obv.: IMP MAXIMINUS PIVS AVG; draped bust of Maximinus Thrax facing right, laureate.

Rev.: [PR]OVIDE-NTIA AVG – S – C; standing personification of Providentia looking left with cornucopia in her left and lowered right hand, in front of her feet globe.

References: BMCRE 6, p. 223, no. 17. p. 230, no. 91–92; RIC 4,2, p. 145, no. 61.

AD 235–236.

177.

J13-Db-17-6

Fig. 177a-b.

AE, Follis.

Wt: 2.87; diam. min.: 1.898; diam. max.: 2.046; 5h.

Thessalonica, Constantine I.

Obv.: CON[STAN-TINVS AVG]; head of Constantine I. facing right, laureate.

Rev.: PROVIDEN-TIAE AVGG – SMTSE; campgate with two turrets, star above, six stone layers, no door.

References: RIC 7, p. 518, no. 153; Robertson (1982), p. 198, no. 287–288.

c. AD 326–330.

178.

J13-Ed-8-3

Fig. 178a-b.

AE.

Uncertain Phoenician city.

Wt: 4.33; diam. min: 1.552; diam. max.: 1.626; 12h.

Obv.: Head of Tyche with corona muralis facing right, veiled.

Rev.: [..]PA[...]; galley with prow to the left, above and below traces of an inscription.

1<sup>st</sup> century BC – 2<sup>nd</sup> century AD.<sup>17</sup>

179.

J13-Gb-8-3

Fig. 179a-b.

AE.

Wt: 6.59; diam. min.: 2.127; diam. max.: 2.131; 12h.

Philadelphia/Arabia, Elagabalus.

Obv.: [AV KEC]AP AN[TωNINOC]; draped and cuirassed bust of Elagabalus facing right, laureate.

Rev.: [ΦΙΑ ΚΟΙΑ - C]YP; chariot with domed canopy upon four pillars to the right, drawn by four horses, above countermark: lying club with handle.

References: Rosenberger (1978), p. 73, no. 47; SNG ANS 6, no. 1398; Spijkerman (1978), p. 256, no. 46.

AD 218–222.

#### Addendum (AHS)

180.

J13\_Dbd\_24\_7

Body, fragmented.

Fig. 180.

Munsell: 5YR 7/6.

H.: 4.5; L.: 5.5; T.: max: 1.2, min.: 1.

Handmade coarse ware fragment with applied “snake” pattern; Hard-fired, rather coarse with some lime inclusions.

References: Sala (2011), fig. 7; Fernández-Tresguerres Velasco (2008), 30-31, fig. 7.

Early Bronze Age

#### Coins from 2012 Campaign (SR)

J12-1.

J12-Af-19-17

Fig. 181a-b.

AE.

Wt: 2.23; diam. min.: 1.554; diam. max.: 1.762; 12h.

Petra; Rabbel II.

Obv.: Jugate busts of Rabbel II. with long hair and Gamilath facing right, laureate.

Rev.: Nabatean letters (Rabbel/Gamilath); two cornucopiae crossed and filleted, between them Nabataean letters in two lines, border of dots.

References: Bellinger (1938), p. 38, no. 79; BMC Arabia, 13 no. 3–7 (esp. no. 6–7); Meshorer (1975), p. 110–111, no. 163; SNG GB 12,2, no. 3622–3626; SNG Copenhagen 7, no. 132–135; SNG ANS 6, no. 1446–1451.

AD 70–106.

J12-2.

J12-B-2-1226

Fig. 182a-b.

AE, Follis.

Wt: 5.96; diam. min.: 2.046; diam. max. 2.313; 5h.

Constantinople; Anastasius I.

Obv.: DN ANAST[A]-SIVS [PPAVC]; draped and cuirassed bust of Anastasius I. facing right, diademed.

Rev.: M – CO[N]; large letter M with cross above, CO[N] below baseline.

References: Bellinger (1966), p. 12–13 no. 16a.1–16a.8; Morrisson (1970), p. 21 no. 1/Cp/AE/11–1/Cp/AE/22.

AD 498–518.

17. The type of the coin is known from several Phoenician mints from the first century BC up to the second century AD. Since the specimen presented here is too badly

preserved to give a precise reading of the inscription the exact mint and date must unfortunately remain uncertain.

- J12-3.  
J12-Bc-27-145  
Fig. 183a-b.  
AE, Semi-Follis.  
Wt: 2.44; diam. min.: 1.956; diam. max.: 2.021; 6h.  
Uncertain, Iustinianus I.  
Obv.: [...]S[...]; draped (and cuirassed?) bust of Iustinianus I. facing right.  
Rev.: K; large letter K.  
*References:* Bellinger (1966), pp. 188–189, no. 360.1–360.28; Morriesson (1970), p. 122, no. 4/X/AE/04–4/X/AE/06.  
AD 527–565.
- J12-4.  
J12-Bc-42-45  
Fig. 184a-b.  
AE, Nummion.  
Wt: 0.70; diam. min.: 0.819; diam. max.: 0.873.  
Obv.: no distinguishable features.  
Rev.: monogram in a laurel-wreath.  
6th – 7th century AD.
- J12-5.  
J12-Ca-39-1  
Fig. 185a-b.  
AE.  
Wt: 1.01; diam. min.: 1.302; diam. max.: 1.306; 12h.  
Constantinople; Theodosius I.  
Obv.: DN THEODO-SIVS PF AVG; draped and cuirassed bust of Theodosius I. facing right, diademed.  
Rev.: SALVS REI-PUBLICAE – CONSA; Nike advancing left, right hand carrying a trophy over her right shoulder and dragging a captive with her left, in left field Chrismon.  
*References:* RIC 9, p. 234, no. 86(b).  
AD 388–392.
- Bibliography**  
Abu Shmeis, A. and Waheeb, M.  
2002 Recent discoveries in the Baptism Site. The pottery. *ADAJ* 46: 561-581.  
Adam-Veleni, P.  
2010 *Glass Cosmos*, Exhibition Catalogue, Thessaloniki.  
Antonaras, A.  
2012 *Fire and Sand. Ancient Glass in the Princeton University Art Museum*, New Haven.  
Arveiller-Dulong, V. and Nenna, M.-D.  
2005 *Les verres antiques du Musée du Louvre II*, Paris.  
Atik, S.  
2009 Late Roman/Early Byzantine Glass from the Marmaray Rescue Excavations at Yenikapi in Istanbul, in *Late Antiquity/Early Byzantine Glass in the Eastern Mediterranean*, E. Lafli (ed.), Izmir: 1–16.
- Avissar, M.  
2005 Tel Yoqne'am: Excavations on the Acropolis, Jerusalem 2005.  
Avissar, M. and Stern, E. J.  
2005 *Pottery of the Crusader, Ayyubid, and Mamluk Periods in Israel*, Jerusalem.  
Bailey, D.  
1988 *A catalogue of the lamps in the British Museum. III. Roman provincial lamps*. London.  
Ball, W., Bowsher, J. Kehrberg, I. Walmsley, A. and Watson, P.  
1986 The North Decumanus and North Tetrapylon at Jerash: an Archaeological and Architectural report, in *Jerash Archaeological Project 1981-1983 I*, F. Zayadine (ed.), Amman: 351-409.  
Barnes, H., Blanke, L. Damgaard, K. Simpson, I. Sørensen, M. L. and Walmsley, A.  
2006 From 'Guard House' to Congregational Mosque: Recent Discoveries on the Urban History of Islamic Jarash. *ADAJ* 50: 285–314.  
Baur, P. V. C.  
1938 *Glassware, in Gerasa. City of the Decapolis*, C. H. Kraeling (ed.), New Haven: 505–546.  
Bellinger, A. R.  
1938 *Coins from Jerash, 1928–1934*. Numismatic Notes and Monographs 81, New York.  
1966 Anastasius I to Maurice. 491–602, in *Catalogue of the Byzantine Coins in the Dumbarton Oaks Collection and in the Whittemore Collection I*, A.R. Bellinger and P. Grierson (eds.), Washington.  
Berlin, A.  
1997 The Plain Wares, in *Tel Anafa II, i. The Hellenistic and Roman Pottery* (Journal of Roman Archaeology Suppl. 10, II, i), Sh. C. Herbert (ed.) Missouri-Colorado.  
Bloch, F.  
2011 *Das umayyadische "Wüstenschloss" und die Siedlung am Ġabal Says, II: Keramik und Kleinfunde*. Mainz.  
Bonifay, M.  
2004 *Etudes sur la céramique romaine tardive d'Afrique*. BAR-IS 1301, Oxford.  
Braemer, F.  
1986 Etudes Complementaires, in *Jerash Archaeological Project 1981-1983 I*, F. Zayadine (ed.), Amman: 61-67.  
Brizzi, M., Sepio, D. and Baldoni, D.  
2010 Italian Excavations at Jarash 2002 – 2009: The Area of the East Propylaeum of the Sanctuary of Artemis and the 'Propylaea Church' Complex, *ADAJ* 54: 345–369.  
Brown, R. M.  
1979 Excavations at 'Iraq el-Emir. *ADAJ* 23, 17–30.  
Bujard, J. and Joguín, M.  
1995 La fortification de Kastron Mayfa'a-Umm ar-

- Rasas, *SHAJ* 5: 241-249. CAIS – the Circle of Iranian Studies: [http://www.cais-soas.com/News/2006/February 2006/19-02.htm](http://www.cais-soas.com/News/2006/February%202006/19-02.htm) (Accessed 12.02.2014)
- Çakmakçı, Z.  
2009 A Typological Approach to Glass Goblet Production from *Late Antiquity to the Middle Ages in the Light of Recent Finds*, in *Late Antiquity/Early Byzantine Glass in the Eastern Mediterranean*, E. Laflı (ed.), Izmir: 49-66.
- Carnivet, P. and Rey-Coquais, J.-P. (eds.)  
1992 *La syrie de Byzance A L'islam VII-VIII siecles*, Damascus.
- Clamer, C.  
1997 *Fouilles archéologiques de Aïn ez-Zâra-Callirrhôé, villégiature hérodiennne*, Paris.
- Clark, V. A.  
1986 The Church of Bishop Isaiah at Jerash, in *Jerash Archaeological Project 1981–1983 I*, F. Zayadine (ed.), Amman: 303–318.
- Clark, V. A., Bowsler, J. M. C. Stewart, J. D. w. contributions by C. Meyer and R. K. Falkner  
1986 The Jerash North Theatre: Architecture and Archaeology 1982 - 1983, in *Jerash Archaeological Project 1981-1983 I*, F. Zayadine (ed.), Amman: 205-302.
- Cytryn-Silverman, K.  
2010 The Ceramic Evidence, in: *Ramla. Excavations North of the White Mosque*, O. Gutfeld, *Qedem* 51, Jerusalem: 97-212.
- Da Costa, K.  
2001 Byzantine and Early Islamic Lamps: Typology and Distribution, in *La céramique Byzantine et proto-Islamique en Syrie-Jordanie (IVe – VIIe Siècles apr. J.- C.)*. *Actes du colloque tenu à Amman les 3, 4 et 5 décembre 1994*, E. Villeneuve and P. M. Watson (eds.), Beyrouth: 241-257.
- Deines, R.  
1993 *Jüdische Steingefässe und pharisäische Frömmigkeit: ein archäologisch-historischer Beitrag zum Verständnis Joh 2,6 und der jüdischen Reinheitshalacha zur Zeit Jesu*, Tübingen
- Crowfoot, J. W., Crowfoot, M. G. and Kenyon, K. M.  
1957 *Samaria-Sebaste. The Objects from Samaria*, London.
- Czurda-Ruth, B.  
2007 *Hanghaus 1 in Ephesos. Die Gläser*, Forschungen in Ephesos VIII/7, Wien.
- Cruikshank Dodd, E.  
1997/98 Christian Arab Painters under the Mamluk, *ARAM* 9-10: 257-288.  
2004 *Medieval Painting in the Lebanon*. Sprachen und Kulturen des Christlichen Orients 08, Wiesbaden.
- Dussart, O.  
1998 *Le Verre en Jordanie et en Syrie du Sud*, BAH 152, Beirut.
- Ettinghausen, R.  
1942 Painting in the Fatimid Period: A reconstruction, *Ars Islamica* IX, 112-124.  
1962 *Arab Painting*, Genova.  
Fernández-Tresguerres Velasco, J. A.  
2008 The “Temple of the Serpents” a Sanctuary in the Early Bronze Age I in the Village of Jabal al-Muṭawwaq (Jordan), *ADAJ* 52, 23-34.
- Ferrazzoli, A. F., and M. Ricci.  
2010 Un centro di produzione delle anfore LR 1: Elaiussa Sebaste in Cilicia, in: S. Menchelli, S. Santoro, M. Pasquinucci and G. Guiducci (eds.), *LRCW3, Late Roman Coarse Wares, Cooking Wares and Amphorae in the Mediterranean. Archaeology and archaeometry. Comparison between western and eastern Mediterranean*, Oxford: G. BAR International Series 2185 (II): 815-826.
- Findlater, G., M. El-Najjar, A.-H. Al-Shiyab, M. O’Hea and E. Easthaugh  
1998 The Wadi Faynan Project: the South Cemetery Excavation, Jordan 1996: a Preliminary Report, *Levant* 30: 69-83.
- Fischer, C. S.  
1938 Tombs, in Gerasa. *City of the Decapolis*. C. H. Kraeling (ed.), New Haven.
- Fisher, M.  
2000 En Boqeq, Mainz.  
Franken, H. J. et al.  
1975 *Potters of a medieval village in the Jordanian vally*, Oxford.
- Friedland, E,  
2012 *The Roman Marble Sculptures from the Sanctuary of Pan at Caesarea Philippi*, Boston.
- Fuller, M.  
2011 Tell Tuneinir (Square 13, locus 29) <http://users.stlcc.edu/mfuller/tuneinir/>; <http://users.stlcc.edu/mfuller/Area2pottery.html> (accessed 4 January 2014)
- Gaitsch, W.  
2005 *Eisenfunde aus Pergamon*. Pergamenische Forschung 14, Berlin – New York.
- Gândilă, A.  
2009 Early Byzantine Coin Circulation in the Eastern Provinces: A Comparative Statistical Approach, *American Journal of Numismatics* 21: 151–226
- Gandolfi, D., G. Murialdo, C. Capelli and M. Bonifay  
2010 Anfore africane di tardo V–VII secolo in Liguria, in: Menchelli et al. (eds.), *LRCW3, Late Roman Coarse Wares, Cooking Wares and Amphorae in the Mediterranean. Archaeology and archaeometry. Comparison between western and eastern Mediterranean*, Oxford: G. BAR International Series 2185 (I): 33–56.
- Gaspar, A., Gomes, A. Mendes, H. C. Pinto, P. Guerra, S. Ribeiro, S. Pimenta, J. and Valongo, A.  
2009 Séculos XI a XVI Ceramicas do seculo XV-XVI

- da Casa do Governador – Castelo S. Jorge, Lisboa in *Actas del VIII Congreso Internacional de Cerámica Medieval II*, J. Zozaya et al., Ciudad Real: 653-672.
- Gawlikowski, M. and Musa, A.  
1986 The Church of Bishop Marianos, in *Jerash Archaeological Project 1981-1983 I*, F. Zayadine (ed.), 137-162.
- Gerber, Y.  
2012 *Classical Period Pottery*. Hesban 11, J. A. Sauer and L. G. Herr (eds.), Michigan: 175-492.
- Geva, H.  
2010 “Stone Artifacts”, in *Jewish Quarter Excavations in the Old City of Jerusalem*, vol. 4, H. Geva, Jerusalem, 154-212.
- Gilboa, A.  
1987 *The typology and Chronology of the Iron Age*, Oxford.
- Goldman, H.  
1950 *Excavation at Gözli Kale, Tarsus I. The Hellenistic and Roman Period*. Princeton.
- Grose, D. F.  
2012 The Pre-Hellenistic, Hellenistic, Roman, and Islamic Glass Vessels, in *Tel Anafa II, ii. Glass Vessels, Lamps, Objects of Metal, and Groundstone and Other Stone Tools and Vessels*, A. M. Berlin – Sh. C. Herbert (eds), Missouri-Colorado: 1–98.
- Gutfeld, O.  
2010 *Ramla, Final Report on the Excavations North of the White Mosque*. Qedem 51: monographs of the Institute of Archaeology, Jerusalem.
- Hadad, S.  
2005 *Islamic glass vessels from the Hebrew University Excavations at Bet Shean*. Qedem 8: monographs of the Institute of Archaeology, Jerusalem.
- Hadad, S.  
2001 *The oil lamps from the Hebrew University excavations at Bet Shean, I*. Qedem 4: monographs of the Institute of Archaeology, Jerusalem.
- Hammond, P. C.  
1965 *The Excavation of the Main Theater at Petra, 1961-1962. Final Report*, London.
- Hayes, J. W.  
1975 *Roman and Pre-Roman Glass in the Royal Ontario Museum*, Toronto.  
1972 *Late Roman Pottery*. London.  
1992 *Excavations at Sarachane in Istanbul II. The Pottery*. Princeton.
- Heidemann, S.  
1998 The Merger of Two Currency Zones in Early Islam. The Byzantine and Sasanian Impact on the Circulation in Former Byzantine Syria and Northern Mesopotamia, Iran 36: 95–112.
- Hirschfeld, Y.  
2007 *En-Gedi Excavations II. Final Report (1996-2002)*. Jerusalem.
- Israeli, Y.  
2003 *Ancient Glass in the Israel Museum. The Eliahu Dobkin Collection and Other Gifts*, Jerusalem.
- Jäggi, C., Meier, H.-R. Brenk, B. and Kehrberg, I.  
1997 New Data for the Chronology of the Early Christian Cathedral of Gerasa: The Third Interim Report on the Jarash Cathedral Project, *ADAJ* 41: 311–320.
- James, L.  
2010 Byzantine mosaics and glass: a problematic relationship, in *Glass in Byzantium – Production, Usage, Analyses*, J. Drauschke and D. Keller (eds.), Mainz: 237-243.
- Jennings, S.  
2004/2005 Vessel Glass from Beirut. BEY 006, 007 and 045, *Berytus* 48/49: 299-304.
- Johns, J.  
1998 The Rise of Middle Islamic Hand-Made Geometrically Painted Ware in Bilad al-Sham (11th – 13th centuries A.D.), in *Colloque international d'archéologie islamique*, R.-P. Gayraud (ed.), Paris: 65-93.
- Jordanov, I.  
2009 *Corpus of the Byzantine Seals from Bulgaria 3,2*, Sofia.
- Kakhidze, A. and Shalikadze, T.  
2009 *Glassware from the Southwestern Littoral of Georgia. Results of Excavations conducted by the N. Berdzenishvili Batumi Research Institute and the Joint British- Georgian Pichvnari Expeditions 1967-2008*. *Pichvnari* 4, Batumi – Oxford.
- Kehrberg, I.  
1989 Selected lamps and pottery from the Hippodrome at Jerash, *Syria* 66: 85-97.  
2001 Ceramic Lamp Production in the 4th and Early 5th Centuries AD at the Hippodrome of Gerasa: an Empirical Study, in: E. Villeneuve and P. M. Watson, *La céramique Byzantine et proto-Islamique en Syrie-Jordanie (IVe – VIIe Siècles apr. J.-C.)*. *Actes du colloque tenu à Amman les 3, 4 et 5 décembre 1994*, Beyrouth: 231-239.
- Keller, D.  
2006 *Petra Ez-Zantur III, Ergebnisse der Schweizerisch-Liechtensteinischen Ausgrabungen. Teil 1: Die Gläser aus Petra*, Mainz: 1–256.
- Kehrberg, I.  
1989 Selected Lamps and Pottery from the Hippodrome at Jerash, *Syria* 66: 85–97.
- Kenkel, F.  
2012 *Untersuchungen zur hellenistischen, römischen und byzantinischen Keramik des Tell Zira'a al-'Arab (Nordjordanien)–Handelsobjekte und Alltagsgegenstände einer ländlichen Siedlung im Einflussgebiet der Dekapolisstädte*. Doctoral Dissertation, Universität zu Köln.

- Kennedy, C. A.  
1963 The Development of the Lamp in Palestine, *Berytus* 14: 67-116.
- Kol-Yaakov, S.  
2000 Hellenistic, Roman, and Byzantine Period Objects, in *Ramat Hanadiv*, Y. Hirschfeld (ed.), Jerusalem.
- Konrad, M.  
2001 Umayyad Pottery from Tetrapyrgium (Qseir es-Seileh), North Syria. Traditions and Innovations, in *La céramique byzantine et proto-islamique en Syrie-Jordanie (Ive-VIIIe siècles apr. J.-C.)*, *Actes du colloque tenu à Amman les 3, 4 et 5 décembre 1994*. Bibliothèque Archéologique et Historique 159, E. Vielleneuve and P. Watson (eds.), Beyrouth: 163-191.
- Kraeling, C. H. (ed.)  
1938 *Gerasa. City of the Decapolis*. New Haven.
- Lapp, P. W.  
1961 *Palestinian Ceramic Chronology*. New Haven.
- Lichtenberger, A. and Raja, R.  
(forthcoming) Towards an understanding of the Dark Ages of Islamic Jerash. Connecting the evidence through texts and archaeology, *Comparative Islamic Studies*.
- Lichtenberger, A., R. Raja and A. H. Sørensen  
(forthcoming) Preliminary registration report of the second season of the Danish-German Jerash Northwest Quarter Project 2012, *ADAJ* 57.
- Lightfoot, C. S.  
2007 *Ancient Glass in National Museums Scotland*, Edinburgh.
- Loeschcke, S.  
1919 *Lampen aus Vindonissa*. Zürich.
- Loffreda, S.  
1996 *La ceramica di Macheronte e dell'Herodion: (90 a.C.-135 d.C.)*, Jerusalem.
- Magness, J.  
1993 *Jerusalem Ceramic Chronology. Circa 200-800 CE*. JSOA/ ASOR Monograph Series, Sheffield.
- Mazar, A.  
2006 *Excavations at Tel Beth-Shean 1989-1996, I. From the Late Bronze Age IIB to the Medieval Period*. The Beth-Shean Valley Archaeological Project. Publication No. 1. Jerusalem.
- McGovern, P. E.  
1989 The Baq'ah Valley Project 1987, Khirbet Umm ad-Dananir and al-Qesir, *ADAJ* 33: 123-136
- McNicoll, A., Smith, R. H. and Hennessy, B.  
1982 *Pella in Jordan I. An interim report on the joint University of Sydney and The College of Wooster Excavations at Pella 1979-1981*. Canberra.
- McNicoll, A. W., Edwards, P. C. Hanbury-Tenison, J. Hennessy, J. B. Potts, T. F. Smith, R. H. Walmsley, A. and Watson, P.  
1992 *Pella in Jordan 2: the Second Interim Report of the Joint University of Sydney and the College of Wooster Excavations at Pella, 1982-1985*, Sydney.
- Mcquitty, A. M., Sarley-Pontin, M. A. Houry, M. Charles, M. P. and Hoppe, C. F.  
1997-98 Mamluk Khirbit Faris, *Aram* 9-10:180-226.
- Meshorer, Y.  
1975 Nabatean Coins, *Qedem* 3: monographs of the Institute of Archaeology, Jerusalem.
- Metzger, I. R.  
1969 *Die hellenistische Keramik in Eretria*. Eretria II. Ausgrabungen und Forschungen, Bern.
- Meyer, C.  
1988 Glass from the North Theater Byzantine church, and soundings at Jerash, Jordan, 1982-1983, in W. E. Rast (ed.), *Preliminary reports of ASOR-sponsored excavations, 1982-85*, *BASOR* Suppl. 25: 175-222.
- 1989 Byzantine and Umayyad Glass from Jerash: Battleship Curves, *ADAJ* 33: 235-244.
- Milwright, M.  
2006 Central and Southern Jordan in the Ayyubid Period: Historical and Archaeological Perspectives, *Journal of the Royal Asiatic Society*, 16, 1: 1-27.
- Morrisson, C.  
1970 *Catalogue des Monnaies Byzantines de la Bibliothèque Nationale I. D'Anastase Ier a Justinien II (491-711)*, Paris.
- Najjar, M.  
1989 Abbasid Pottery from el-Muwaqqar, *ADAJ* 33: 305-322.
- Nassar, M.  
2004 *The Architectural Elements and Decoration at Gerasa (Jerash) during the Roman Period (Typological and Comparative Studies)*, Berlin.
- Negev, A.  
1986 *The Late Hellenistic and early Roman Pottery of Nabatean Oboda*, *Qedem* 22: monographs of the Institute of Archaeology, Jerusalem.
- Oliver, A.  
1980 *Ancient Glass in the Carnegie Museum of Natural History*, Pittsburgh.
- Owiss, I.  
1985 A Roman-Byzantine Tomb at Jerash, *ADAJ* 29: 31-41 (arabic section).
- Piazza, M. G, et al.  
1984 Soundings in the intermediate Terrace of the sanctuary of Artemis at Garasa, *Mesopotamia* 18-19:113-134.
- Piccirillo, M. and M. Russan  
1976 A Byzantine Church at ed-Deir (Ma'in), *ADAJ* 21: 61-70.
- Pierobon, R. et al.  
1984 Centro scavi de Torino per il medio oriente e l'asia, *Mesopotamia* 18-19: 85-111.

- 1986 The Area of the kilns, (contributed to: R. Parapetti, The Italian Activity within the Jerash Project 1982-1983), in *Jerash Archaeological Project 1981-1983 I*, F. Zayadine (ed.), Amman: 184-188.
- Pollak, R.  
2006 The glass, in Tel Tanninim. *Excavations at Krokodeilon Polis 1996-1999*, R. R. Stieglitz (ed.), Boston: 155-193.
- Racioppi, P.  
2014 Painted wooden ceiling of the Palatine Chapel, in *Discover Islamic Art. Place: Museum With No Frontiers*, 2014 (web quote).[http://www.discoverislimicart.org/database\\_item.php?id=monument;ISL;it;Mon01;10;en&cp](http://www.discoverislimicart.org/database_item.php?id=monument;ISL;it;Mon01;10;en&cp) (accessed on 11.01.2014).
- Rasson, A.-M.  
1986 Matériel Céramique de la Deuxième Moitié du IIIème Siècle ap. J.-C, in *Jerash Archaeological Project 1981-1983 I*, F. Zayadine (ed.), Amman: 67-69.
- Rasson A.-M. and Seigne, J.  
1989 Un Citerne Byzantino-Omeyyade sur le Sanctuaire de Zeus, *Syria* 66: 117-151.
- Rast, W. E. and Schaub, R.T.  
1974 Survey of the Southeastern Plain of the Dead Sea, 1973, *ADAJ* 19: 5-53.
- Riis, P. J.  
1969 *Hama. Fouilles et recherches, 1931-1938. IV 3. Petits objets médiévaux sauf les verreries et poteries*. Copenhagen.
- Riis, P. J. and Buhl, M.-L.  
1990 *Hama. Fouilles et recherches, 1931-1938. II 2. Les objets de la période dite Syro- Hittite (Âge du Fer)*. Copenhagen.
- Robertson, A. S.  
1982 Diocletian (Reform) to Zeno, in *Roman Imperial Coins in the Hunter Coin Cabinet*. University of Glasgow 5, Oxford.
- Rosenberger, M.  
1978 *The Coinage of Eastern Palestine and Legionary Countermarks, Bar-Kokhba Overstrucks*. The Rosenberger Israel Collection 4, Jerusalem.
- Rosenthal, R., and Sivan, R.  
1978 *Ancient lamps in the Schloessinger collection*. Qedem 8: monographs of the Institute of Archaeology. Jerusalem.
- Rotroff, S. I.  
1997 *Hellenistic Pottery. Athenian and Imported Wheelmade Table Ware and Related Material*. The Athenian Agora 29, Princeton.
- Sala, M.  
2011 Sanctuaries, Temples and Cult Places in Early Bronze I southern Levant, Vicino e Medio Oriente XV, Rome, 1-32.
- von Saldern, A.  
1974 *Kunstmuseum Düsseldorf, Glassammlung Hentrich. Antike und Islam*, Düsseldorf.
- 1980 *Ancient and Byzantine Glass from Sardis*. Sardis 6, Cambridge-London.
- Saller, S.  
1967 Hellenistic to Arabic remains at Nebo, Jordan, *LA* 17, 5-64.
- Sauer, J. A. and Herr, L. G. (eds.)  
2012 *Ceramic Finds: Typological and Technological Studies of the Pottery Remains from Tell Hesban and Vicinity*. Hesban 11, Michigan.
- Schaefer, J.  
1986 An Umayyad Potters' Complex in the North Theater, Jerash, in *Jerash Archaeological Project 1981-1983 I*, F. Zayadine (ed.), Amman: 411-459.
- Schlumberger, D.  
1986 *Qasr el-Heir el Gharbi*, Paris.
- Scholl, T.  
1986 The chronology of Jerash lamps: a preliminary report, in *Jerash Archaeological Project 1981-1983 I*, F. Zayadine (ed.), Amman: 163-166.
- Schmid, S.G.  
1993 *Die Feinkeramik der Nabatäer, Petra und die Weihrauchstrasse*, Zürich.
- Smith, R. H.  
1973 *Pella of the Decapolis I. The 1967 season of the College of Wooster Expedition to Pella*, Wooster.
- Schwarzer, H.  
2009a Spätantike und byzantinische Glasfunde aus Alexandria Troas, in *Late Antiquity/Early Byzantine Glass in the Eastern Mediterranean*, E. Laflı (ed.), Izmir: 67-84.
- Schwarzer, H.  
2009b Spätantike ,byzantinische und islamische Glasfunde aus Pergamon, in *Late Antiquity/Early Byzantine Glass in the Eastern Mediterranean*, E. Laflı (ed.), Izmir: 85-109.
- Seigne, J w. contributions by C. augé, F. Braemer, J. Dentzer-Feydy, E. de Montlivault, O Dussart, P.-L. Gatier and A.-M. Rasson  
1986 Recherches sur le sanctuaire de Zeus a Jerash, in *Jerash Archaeological Project 1981- 1983 I*, F. Zayadine (ed.), Amman: 29-106.
- Shepherd, J. D.  
1999 The Glass, in *Nicopolis ad Istrum: A Roman to Early Byzantine City*, A. G. Poulter (ed.), London: 297-378.
- Smith, R. H.  
1981 Preliminary Report on a second Season of Excavation at Pella, Jordan. *ADAJ* 25, 311-326
- Spaer, M.  
2001 *Ancient Glass in the Israel Museum. Beads and Other Small Objects*, Jerusalem.

- Spijkerman, A.  
1978 *The Coins of the Decapolis and Provincia Arabia*. Studii Biblici Franciscani Collectio Maior 25, Jerusalem.
- Stacey, D.  
2004 Excavations at Tiberias, 1973-1974, The Early Islamic Periods. IAA Reports 21, Jerusalem.
- Stern, E. M.  
2001 *Römisches, byzantinisches und frühmittelalterliches Glas 10 v. Chr.–700 n. Chr., Sammlung Ernesto Wolf, Ostfildern-Ruit*.
- Strobel, S. and Wimmer, S.  
2003 *Kallirrhoë ('Ēn ez-Zāra). Dritte Grabungskampagne des Deutschen Evangelischen Instituts für Altertumswissenschaft des Heiligen Landes und Exkursionen in Süd-Peräa, Wiesbaden*.
- Teichner, F. and Schierl, T.  
2009 A olaria medieval da Porta da Lagoa em Evora (Alto Alentejo, Portugal), in *Actas del VIII Congreso Internacional de Cerámica Medieval, 2, J. Zozaya, M. Retuerce, M. A. Hervas, and A. de Juan (eds.), Ciudad Real: 975-986*.
- Tholbecq, L.  
1997-1998 *The Mamluks and Early Ottoman Period in Bilad Al-Sham: History and Archaeology*. Paris.
- Thuesen, I.  
1988 *Hama. Fouilles Et Recherches 1931-1938 I. The Pre- and Protohistoric Periods*. Copenhagen.
- Tyers, P. A.  
1996/2012 Dressel 2-4 Amphoras, <http://potsherd.net/atlas/Ware/DR2-4> (Accessed 13-01.2014)
- Uscatescu, A.  
1995 Jarash Bowls and other related local wares from the Spanish excavations at the Macellum of Gerasa (Jarash). *ADAJ* 34: 365–408.  
1996 *La Cerámica del Macellum de Gerasa* (Yaras, Jordania). Madrid.
- Uscatescu, A.  
2001 L'apport des fouilles du macellum (Jérash, Jordanie) à la connaissance des céramiques byzantine tardives de Gerasa, in *La Céramique Byzantine et proto-islamique en syrie-Jordanie (IV-VIII Siècles Apr. J.-C.) Actes du colloque tenu à Ammen les 3, 4 et 5 décembre 1994*, E. Villeneuve and P. M. Watson (eds.), Beyrouth: 59-66.
- Waldbaum, J. C.  
1983 *Metalworks from Sardis. The Finds through 1974*. Sardis 8, Cambridge-London.
- Walker, B. J. (ed.)  
2009 *Reflections of Empire: Archaeological and Ethnographic Studies on the Pottery of the Ottoman Levant*, *AASOR* 64, Boston.
- Walker, B.  
2012 *The Islamic period; Deep Hemispherical Bowl*. Hesban 11, Michigan: 507-596.
- Walmsley, A.  
1995 Tradition, Innovation, and Imitation in the Material Culture of Islamic Jordan: The First Four Centuries. *SHAJ* 5: 657-668.  
1997-98 Settled Life in Mamluk Jordan – Views of the Jordan Valley from Fahl (Pella), *ARAM* 9-10: 129-143.
- Walmsley, A., L. Blanke, K. Damgaard, A. Mellah, S. McPhillips, L. Roenje, I. Simpson and F. Bessard  
2008 A Mosque, shops and bath in central Jerash: The 2007 season of the Islamic Jerash Project, *ADAJ* 52: 109-137.
- Walmsley, A. and R. H. Smith  
1992 The Islamic Period, in *Pella in Jordan 2*, A. W. McNicoll, P.C. Edwards, J. Hanbury-Tenison, J.B. Hennessy, T. F. Potts, R. H. Smith, A. Walmsley and P. Watson, Sydney 1992, 183-198.
- Watson, P.  
1989 Jerash Bowls: Study of a provincial group of byzantine decorated fine ware, *Syria* 66: 223-261.  
1992 Change in Foreign and Regional Economic Links with Pella in the Seventh Century A.D.: The Ceramic Evidence, in *La Syrie de Byzance à l'Islam: VIIe–VIIIe siècles: actes du colloque international Lyon – Maison de l'Orient méditerranéen, Paris – Institut du monde arabe, 11-15 Septembre 1990*, P. Canivet and J.-P. Rey-Coquais (eds.), Damascus: Institut français de Damas: 233–247.
- 2008 The Byzantine Period, in *Jordan. An Archaeological Reader*, R.B. Adams (ed.), London, 443-482.
- Weber, T. M.  
2002 *Gadara–Umm Qes. Gadara Decapolitana: Untersuchungen zur Topographie, Geschichte, Architektur und der Bildenden Kunst einer "Polis Hellenis" im Ostjordanland*. Abhandlung des Deutschen Palästina Vereins 30, Wiesbaden.
- Weinberg, G. D.  
1988 *Excavations at Jalame. Site of a Glass Factory in Late Roman Palestine*, Columbia, Missouri.
- Weinberg, G. D. and Stern, E. M.  
2009 *Vessel Glass*, The Athenian Agora 34, Princeton.
- Whitcomb, D.  
2008 The Umayyad and Abbasid Periods, in *Jordan. An Archaeological Reader*, R. B. Adams (ed.), London, 483-493.
- Whitehouse, D.  
1997 *Roman Glass in The Corning Museum of Glass I*, New York.  
2001 *Roman Glass in The Corning Museum of Glass II*, New York.
- Zayadine, F.  
1974 Excavations at Petra (1973-1974). *ADAJ* 19: 135-151.



- Zayadine, V. A.  
 1986 Part II the archaeology of the Roman theatre, in *Jerash Archaeological Project 1981- 1983 I*, F. Zayadine (ed.), Amman: 231-302.
- Zozaya, J., M. Retuerce, M. A. Hervás and A. de Juan (eds.)  
 2009 *Actas del VIII Congreso Internacional De Ceramica Medieval En El Mediterraneo, Ciudad Real-Almagro del feb. al 3 de marzo de 2006*, 2, Ciudad Real.
- List of abbreviated titles**
- BMC Arabia  
 G.F. Hill,  
 1981 Catalogue of the Coins of Arabia, Mesopotamia and Persia, in: *A Catalogue of the Greek Coins in the British Museum* 28, Bologna. BMCRE 6.
- LIMC  
 Kahil, L.  
 1984 Artemis, in *Lexicon Iconographicae Mythologicae Classicae*, 618-753.
- R.A.G.  
 2005 Carson, Severus Alexander to Balbinus and Pupienus, in *Coins of the Roman Empire in the British Museum* 6, H. Mattingly et al. (eds.), London.
- SNG ANS 6  
*Sylloge Nummorum Graecorum*. The Collection of the American Numismatic Society 6. Palestine–South Arabia, New York.
- SNG Copenhagen 7  
*Sylloge Nummorum Graecorum*. The Royal Collection of Coins and Medals. Danish National Museum 7. Cyprus–India, West Milford.
- SNG GB 12,2  
*Sylloge Nummorum Graecorum*. The British Academy 12. The Hunterian Museum. University of Glasgow 2. Roman Provincial Coins Cyprus–Egypt, Oxford.
- RIC 4,2  
 Mattingly, H., Sydenham, E. A. and Sutherland, C. H. V.  
 1938 *The Roman Imperial Coinage* 4,2. Macrinus to Pupienus, London.
- RIC 7  
 P. M. Bruun,  
 1966 Constantine and Licinius, in *The Roman Imperial Coinage* 7, C.H.V. Sutherland, D. Litt and R.A.G. Carson (eds.), London.
- RIC 9  
 J.W.E. Pearce,  
 1951 Valentinian I – Theodosius I, in *The Roman Imperial Coinage* 9, H. Mattingly, C.H.V. Sutherland and R.A.G. Carson (eds.), London.
- Wroth, W.  
 1966 *Imperial Byzantine Coins in the British Museum*, Chicago.

